

Алматы (7273)495-231
Ангарск (3955)60-70-56
Архангельск (8182)63-90-72
Астрахань (8512)99-46-04
Барнаул (3852)73-04-60
Белгород (4722)40-23-64
Благовещенск (4162)22-76-07
Брянск (4832)59-03-52
Владивосток (423)249-28-31
Владикавказ (8672)28-90-48
Владимир (4922) 49-43-18
Волгоград (844)278-03-48
Вологда (8172)26-41-59
Воронеж (473)204-51-73
Екатеринбург (343)384-55-89

Ижевск (3412)26-03-58
Иваново (4932)77-34-06
Иркутск (395)279-98-46
Казань (843)206-01-48
Калининград (4012)72-03-81
Калуга (4842)92-23-67
Кемерово (3842)65-04-62
Киров (8332)68-02-04
Коломна (4966)23-41-49
Кострома (4942)77-07-48
Краснодар (861)203-40-90
Красноярск (391)204-63-61
Курск (4712)77-13-04
Курган (3522)50-90-47
Липецк (4742)52-20-81

Магнитогорск (3519)55-03-13
Москва (495)268-04-70
Мурманск (8152)59-64-93
Набережные Челны (8552)20-53-41
Нижний Новгород (831)429-08-12
Новокузнецк (3843)20-46-81
Ноябрьск (3496)41-32-12
Новосибирск (383)227-86-73
Ноябрьск (3496)41-32-12
Омск (3812)21-46-40
Орел (4862)44-53-42
Оренбург (3532)37-68-04
Пенза (8412)22-31-16
Петрозаводск (8142)55-98-37
Псков (8112)59-10-37

Пермь (342)205-81-47
Ростов-на-Дону (863)308-18-15
Рязань (4912)46-61-64
Самара (846)206-03-16
Саранск (8342)22-96-24
Санкт-Петербург (812)309-46-40
Саратов (845)249-38-78
Севастополь (8692)22-31-93
Симферополь (3652)67-13-56
Смоленск (4812)29-41-54
Сочи (862)225-72-31
Ставрополь (8652)20-65-13
Сыктывкар (8212)25-95-17
Сургут (3462)77-98-35
Тамбов (4752)50-40-97

Тверь (4822)63-31-35
Тольяти (8482)63-91-07
Томск (3822)98-41-53
Тула (4872)33-79-87
Тюмень (3452)66-21-18
Улан-Удэ (3012)59-97-51
Ульяновск (8422)24-23-59
Уфа (347)229-48-12
Хабаровск (4212)92-98-04
Чебоксары (8352)28-53-07
Челябинск (351)202-03-61
Череповец (8202)49-02-64
Чита (3022)38-34-83
Якутск (4112)23-90-97
Ярославль (4852)69-52-93

Киргизия (996)312-96-26-47

Россия (495)268-04-70

Казахстан (772)734-952-31

<https://gallicassina.nt-rt.ru> || gny@nt-rt.ru

КАТАЛОГ на клапаны с двойной блокировкой и выпуском воздуха

DUAL SEAL D.B&B



PLUG VALVES



GALLI&CASSINA in the World:

Our products are being used in the most important Plants and Gas Pipelines all over the world.

Galli&Cassina Plug Valves are used in the most important hydrocarbon plants and gas pipelines all over the world.

For over 70 years Galli&Cassina has been committed to provide service to the end-users with a full range of products ensuring total customer's satisfaction.

Galli&Cassina is represented by sales offices worldwide and you are requested to contact our main office in Italy for more details.





Galli&Cassina Profile



Galli&Cassina is a prominent Italian Company, leader in Design and manufacturing a complete range of Lubricated Plug valves.

The company is located in Solaro near to Milan (Italy)

Galli&Cassina was founded in 1919, and it is one of the oldest Italian companies which today is still in the valve business; in the beginnings G&C business activity was concentrated in the production of valves to serve the domestic growing market.

After the first ten years the company gradually turned its production towards the newly born Chemical Industry.

G&C was the first in Italy to produce valves in stainless steel and other special material in light with the demand of the

most important chemical companies. It was not possible to expand further the Milan factory which was built in 1930 and enlarged after the second world war.

Since 1991 **Galli&Cassina** has moved to a new location in Solaro (Milan) with modern building and facilities after 30 years of experience in chemical valves.

Galli&Cassina started the production of Plug Valves to serve the Oil & Gas worldwide market becoming one of the most significant supplier for all International Oil & Gas companies across the world.



with extensive offices and workshop covering 12.000 sq.mt. area including 5000 sq.mt. of covered space.





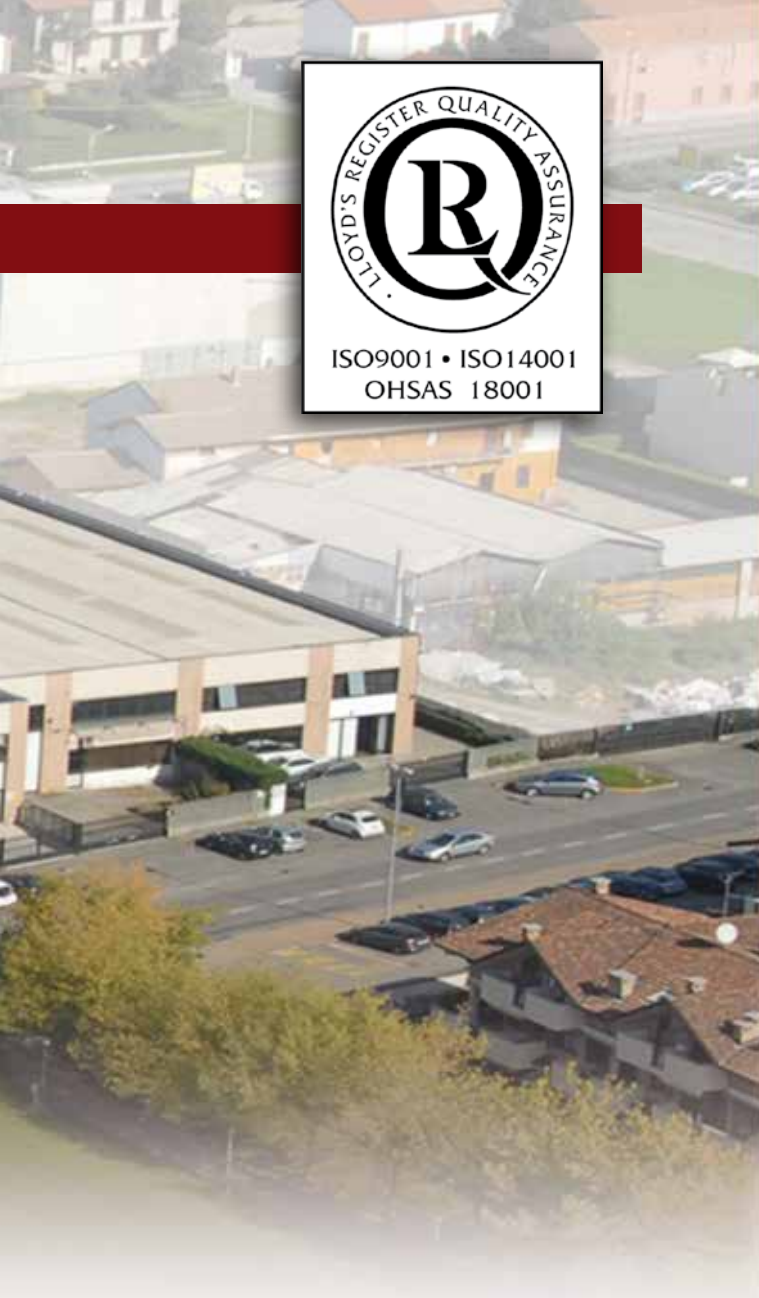

1. WORKSHOP & OFFICES.



2. WELDING.



3. MATERIAL RECEIVING.



4. TESTING AND INSPECTION.



5. PACKING AND SHIPPING.



6. WAREHOUSE.

Galli&Cassina is a world's leading manufacturer of plug valves for Oil & Gas and Chemical application since 1919. The company is located in Solaro near Milan (Italy) with extensive offices and workshop covering a 12.000 sq.mt. area including 5.000 sq.mt. of covered space.

Galli&Cassina's Quality Assurance System ISO 9001 has been assessed, approved and certified by Lloyd's Register as well as the Environmental Management System ISO 14001 and Occupational Health & Safety Systems

ISO 18001. Valves design is fully developed by **Galli&Cassina** technical department and it complies to API 6D requirements other than the applicable international standards.

Galli&Cassina sales activity covers most of the continents with a leading and growing presence in Europe, Middle East, North & South America and Far East thanks also to an extensive service network with subsidiaries, branch offices and distributors.

Galli&Cassina Dual Seal Double Block & Bleed valve has been included in the products range in order to merge **Galli&Cassina** consolidated plug valves know how with the new "Dual Seal" technology to approach a wider range of applications.



Galli&Cassina Profile





DBB Technical Descriptions

The Galli&Cassina Dual Seal Double Block & Bleed valve is a single valve that simultaneously blocks both the upstream and downstream flow while allowing the user to verify tightness using a manual or automatic body bleed system. They are designed for applications where positive shut-off, verifiable zero leakage and double block and bleed (DBB) capabilities are required.

The **DBB** feature is ensured by two slips with bonded in seals sliding on the tapered plug to achieve upstream and downstream tight shut-off sealing. During opening operation the plug is pulled up allowing the sliding slips to retract, than the plug starts the 90° rotation taking the slips completely out of the flow. During closing operation, the tapered plug takes the slips back to position, than it is pushed down forcing the slips against the body seats, providing the tight shut off sealing.

Main Features:

- Easy in line maintenance: Dual Seal Plug Valves have a design which makes simple the maintenance operation. The body slips can be replaced with the valve installed in line (depressurized and drained), just by removing the lower bonnet and replacing the slips with a pair of new ones.

- Long service life and Low Operational Torque: During valve operation the soft seals bonded in the slips are in contact with body seats only at the end of the expanding operation, while during the 90° run they are retracted, therefore they are not affected by friction against body seat.

- Verifiable Positive sealing: Individual seat sealing effectiveness can be easily verified by the operator at completion of every valve operation through body cavity bleed valve.
- Quick opening and closing time: Valve simple design makes very quick the opening and closing operation.

Main Media Handled:

- Refined Oil Products, such as Diesel, Kerosene, Gasoline, Jet Fuel etc..

Main Applications :

- Meter Stations.
- Integral Manifolds.
- Loading & Unloading Fuel tank farm.
- Tank Storage Isolations.
- Hydrant Systems Isolations.



Range Size: Dual Seal Plug valves

Class:
ASME/ANSI
150 up to Class 1500 Lb
Size:
DN 2" up to 36"
Class 150 - 300.

DN 2" up to 24"
Class 600.

DN 2" up to 10"
Class 900 - 1500.

Range Temperature:
-29 C° to 220 C°
(-22 F° to 428 F°)

**Over size available
upon Customer's
requested.**



Index

Company Profile 2/5

Galli&Cassina Products

DBB Technical Descriptions	6
Product Identification System	8
Material Selection	9
Typical Valve Assembly	10
Pressure Relief System	11
Fire Safe Test	12
Available Test	13
Applicable Standard-Specification	14
Pressure Test Tables in Accordance with API598 & API 6D.	15
Hydraulic Pressure Test Duration	

Valve Dimensions:

ANSI Class 150 (PN 20)	16-17
ANSI Class 300 (PN 50)	18-19
ANSI Class 600 (PN 100)	20-21
ANSI Class 900 (PN 150)	22
ANSI Class 1500 (PN 250)	23

Engineering Data

Quality Assure Programme	24
Quality Assure System	
Quality Assure Development	
Customer Service	25
Conversion Table	26-27
Temperature Conversion Table	28
Pressure/Temperature Rating According to ASME B16.34-2013	29
Chemical and Mechanical Requirements for Body, Plug & Cover material (Forged/Bar)	30-31
Chemical and Mechanical Requirements for Body, Plug & Cover material (Casting)	32-33
Plug Valve Dimensions According to API Std. 6D/ISO14313	34
Plug valve Applications	35
Linear Actuators Availability	36

Galli&Cassina reserves the right to edit any data within this catalog whenever necessary.





Product Identification System

Identification numbers here shown are used to describe essential features of Galli & Cassina valves.

Example: 100 EPCC01R0001

100	Size	<ul style="list-style-type: none"> • 1/2" 015 • 3/4" 020 • 1" 025 • 1 1/2" 040 • 2" 050 • 3" 080 • 4" 100 • 6" 150 • 8" 200 • 10" 250 • 12" 300 • 14" 350 • 16" 400 • 18" 450 • 20" 500 • 22" 550 • 24" 600 • 30" 750 • 36" 900
EP	Valve Type	EXPANDING PLUG VALVE
C	Pattern	<ul style="list-style-type: none"> • C Short • R Regular • F ** Full bore
C	Valve Operator Type	<ul style="list-style-type: none"> • C Handwheel • R Gear • E Gear with Electric Motor • A Actuator (Pneumatic or Gas overoil) • B Bare Stem
01	Working Pressure Class	API 6D Valves <ul style="list-style-type: none"> • 150 01 • 400 04 • 900 09 • 300 03 • 600 06 • 1500 15
R	Valve End Connection	<ul style="list-style-type: none"> • R RF Flange • W Butt Weld • B Butt Weld by Flange • J Ring Joint Flange
P	Optional Special Features	<ul style="list-style-type: none"> • T Completely Buried • P Partially Buried • N Pups • J Partially Buried and Pups
0001	Internal Material Identification	According to client's materials requirement

The Code used as sample above (100 EPCC01 R 0001) identifies a: DN 100 (4") - Expanding plug valve - Short pattern - Handwheel operated - ANSI 150 (PN 20) - Flange ends connection - Standard carbon steel materials suitable for ambient and higher temperature service.

* See G&C blue catalogue "LUBRICATED PLUG VALVES STANDARD & JACKETED TYPE".

** See G&C green catalogue "LUBRICATED PLUG VALVES PRESSURE BALANCED FULL BORE TYPE".

*** See G&C silver catalogue "FULL BORE PRESSURE BALANCED TYPE WITH LGC* LUBRICATION SYSTEM".



Material Selection Guide for GALLI&CASSINA Valves

Trim materials are designed according to the service conditions.

- 1** Standard Carbon Steel Body and Plug. (ASTM-A216 WCB/WCC material) suitable for general services.
- 2** Carbon Steel Body and Plug (A352 LCB/LCC material) suitable for low temperature services.
- 3** Carbon Steel Body and Plug (ASTM A216WCB/WCC material) suitable for "SOUR SERVICE" (H₂S and CO₂) according to NACE-MR.01.75/Latest Edition.
- 4** Special Austenitic (6MO) and Ferritic-Austenitic Stainless Steel (Duplex and Superduplex) suitable for sea water and corrosive services.
- 5** Other materials upon request.

Standard Design Categories (Typical Construction Materials)

Trim Service	Body/Cover	Plug & Stem	Slip	Slip Seal	Bolting
1 Standard service Natural gas Hydrocarbons	ASTM A105 ASTM A216 WCB/WCC Max C 0.25%	ASTM A105 ASTM A216 WCB/WCC	ASTM A105 ASTM A216 WCB/WCC	VITON NBR	ASTM A193-B7M ASTM A194-2HM
2 Low temperature Natural gas Hydrocarbons	ASTM A350-LF2 ASTM A352 LCB/LCC Max C 0.23%	LCB/LCC ASTM A352 ASTM A350-LF2 ASTM 182 F6 A	ASTM A350-LF2 ASTM 182 F6 A ASTM A352- LCB/LCC	VITON	ASTM A320-L7 ASTM A194 Gr.7
3 Sour Service (H ₂ S and CO ₂) Hydrocarbon s	ASTM A105 ASTM A216 WCB/WCC Max C.0.23% Max HRC22	ASTM A105 ASTM A216 WCB/WCC Max C.0.23% Max HRC22	ASTM A105 PTFE WCB/WCC Max C.0.23% Max HRC22	VITON	ASTM A193-B7M ASTM A194-2HM MAX HRC22
4 Sea Water	UNS S31254 ASTM A 351 CK3MCuN (6MO)	UNS S31254 ASTM A 351 CK3MCuN (6MO)	UNS S31254	VITON	ASTM A453 Gr.660A
	UNS S31803 ASTM A 890 J92205 (Duplex 22% Cr)	UNS S31803 ASTM A 890 J92205 (Duplex 22% Cr)	UNS S31803	VITON	ASTM A453 Gr.660A UNS S32760
	UNS S32750 ASTM A 890 J93404 (Super duplex 25% Cr)	UNS S32750 ASTM A 890 J93404	UNS S32750	VITON	UNS S32760
	UNS S32760 ASTM A 890 J93380 (Super duplex 25% Cr)	UNS S32760 ASTM A 890 J93380	UNS S32760	VITON	UNS S32760

Notes: Other slip seal elastomer upon request.

Typical Valve Assembly

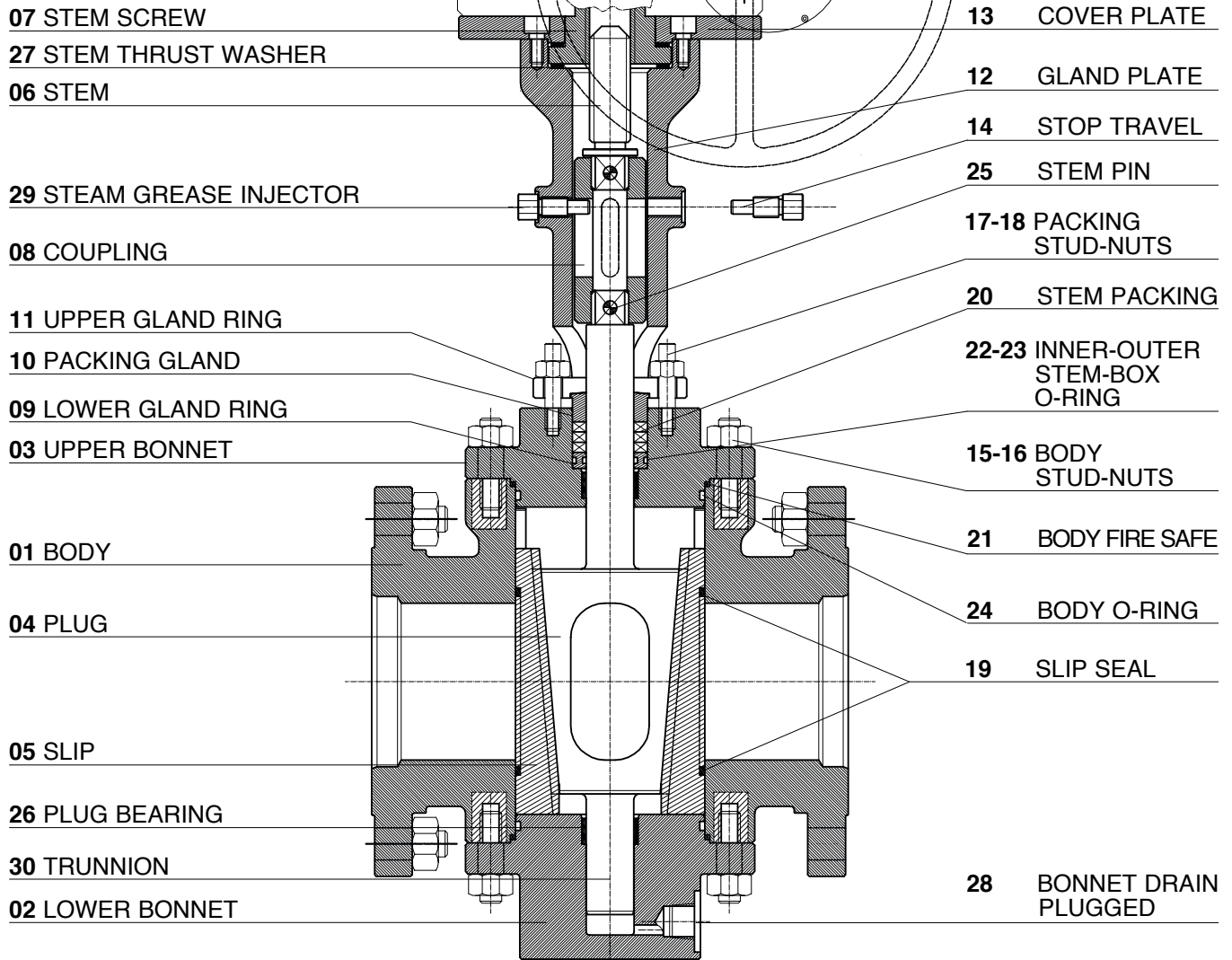

Bill of Components

Ref. No	Part Name	Material	Ref. No	Part Name	Material
01	Body	ASTM A216 GR.WBC/WCC	15	Body Stud	ASTM A193 GR.B7
02	Lower Bonnet	ASTM A105N	16	Body Nuts	ASTM A194 GR.2H
03	Upper Bonnet	ASTM A105N	17	Packing Stud	ASTM A193 GR.B7
04	Plug	ASTM A105N	18	Packing Nuts	ASTM A194 GR.2H
05	Slip	+Nickel Plating 0,003" AISI 4140+VITON GF	19	Slip Seal	VITON - GF
06	Stem	+Nickel Plating 0,003" AISI 4140	20	Stem Packing	Graphite
07	Stem Crew	Bronze B148	21	Body Fire Safe	Graphite
08	Coupling	ASTM A182 F6A CL.2	22	Inner Stem-Box O-Ring	VITON GF
09	Lower Gland Ring	ASTM A182 F316	23	Outer Stem-Box O-Ring	VITON GF
10	Packing Gland	ASTM A182 F316	24	Body O-Ring	VITON GF
11	Upper Gland Ring	AISI 4140	25	Stem Pin	AISI 4140
12	Gland Plate	ASTM A216 GR.WBC/WCC	26	Plug Bearing	S.S. du Dry - 316
13	Cover Plate	ASTM A105N	27	Stem Thrust Washer	S.S. du Dry - 316
14	Stop Travel	ASTM A FA CL.2	28	Bonnet Drain - Plugged	S.S. 304
			29	Stem Grease Injector	S.S. 304
			30	Trunnion	S.S. 304



Pressure Relief System

The Automatic Body Bleed Valve provides visual, positive assurance that the Dual Seal has sealed completely at each cycling operation and prevents thermal pressure buildups in the body cavity.

An automatic bleed valve connected to the body cavity of the main valve is mechanically opened by the valve operator when the Dual Seal is closed. Seal integrity is indicated by viewing the discharge of the bleed valve.

When the Dual Seal is opened, the bleed valve is automatically closed by the combination of line pressure and the spring in the bleed valve.

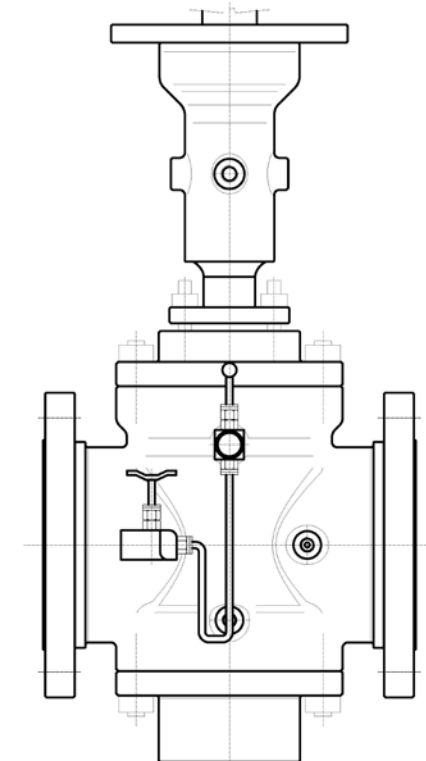
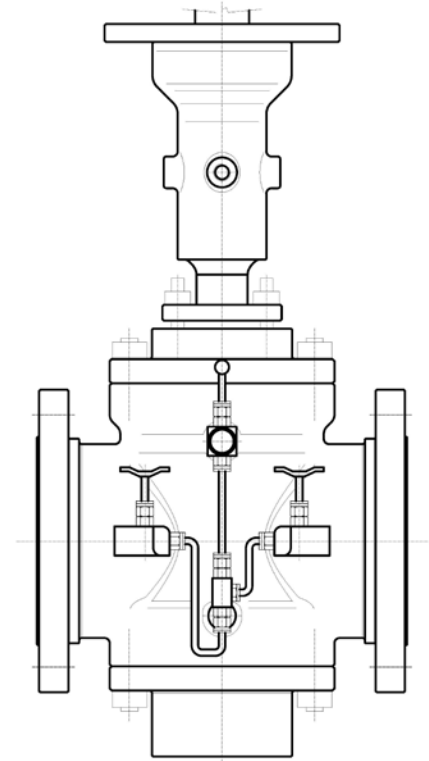
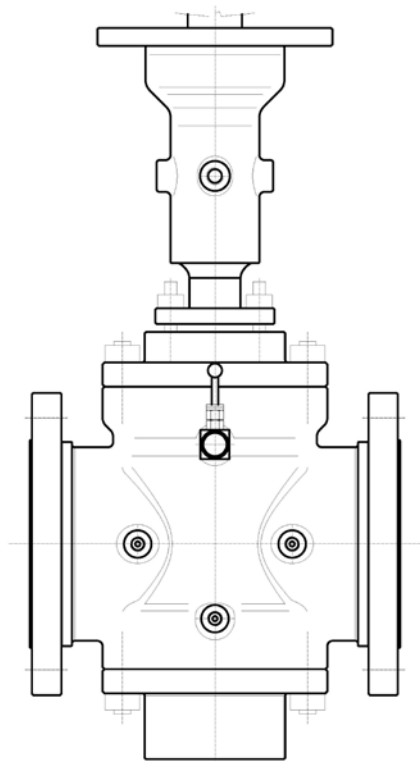

Manual Bleed Valve to Atmosphere.*

A manual bleed valve is connected to body cavity, it can be opened after the Dual Seal valve is closed, in this way the seal effectiveness can be checked immediately. This bleed valve must be closed before to reopen the Dual Seal valve.

**Standard feature on Galli & Cassina Dual Seal Valves.*

Manual Relief to Atmosphere with Thermal Relief from Downstream and Body to Upstream.

This system is designed to relieve the overpressure of valve body cavity and downstream to upstream due temperature floating when the valve is closed. Further to standard manual bleed to atmosphere, this system has the addition of a thermal relief from downstream to upstream. The thermal relief system relieve to upstream when differential pressure exceeds 25 psi. The above system works when the valves part of the thermal relieve system are kept open and the manual body bleed valve to atmosphere is closed.

Manual Bleed Valve with Thermal Relief to Upstream.

This system is designed to relieve the overpressure of valve body cavity and to upstream due to temperature floating when the valve is closed. Further to standard manual bleed to atmosphere, this system has the addition of a thermal relief from valve body cavity to upstream. The thermal relief system relieve to upstream when differential pressure exceeds 25 psi.



Available Tests

Type of Test	Applicable Standards	Performance
X AND GAMMA RAYS	ANSI B16.34 - Annex-B ASME VIII - Div.1 - MSS - SP 54 ASTM E446 - E186 - E280	100% all butt welding ends and body.
DYE PENETRANT	ASME V - art.6 and 24 - ASTM E142 100% ANSI B16.34 - Annex-D MSS-SP-93	All butt welding ends
MAGNETIC - PARTICLES (Dry and wet)	ASME V - art.7 and 25 ANSI B16.34 - Annex C - MSS - SP 53	100% of all valves
ULTRASONIC	ASME V - art.4 and 23 ASME VIII - Div.1 - ASTM - A388	Upon customer request
VISUAL AND DIMENSIONAL	MSS - SP 55 ANSI B16.5 - B16.10 API 6D - (Table 4.2)	100% of rough and finished machined components and assembled valves
HARDNESS	NACE - MR.01.75 Latest Edition	100% of wetted components
HYDROSTATIC AND PNEUMATIC	API - 6D - API 598 BS 6755 - Part.1 - MSS - SP 61	100% of all valves
OPERATION TORQUE	API - 6D	Upon customer request
HIGH PRESSURE CLOSURE	API - 598 - Par. 4-5	Upon customer request
POSITIVE MATERIAL IDENTIFICATION	ASTM A751	100% of pressure containing components

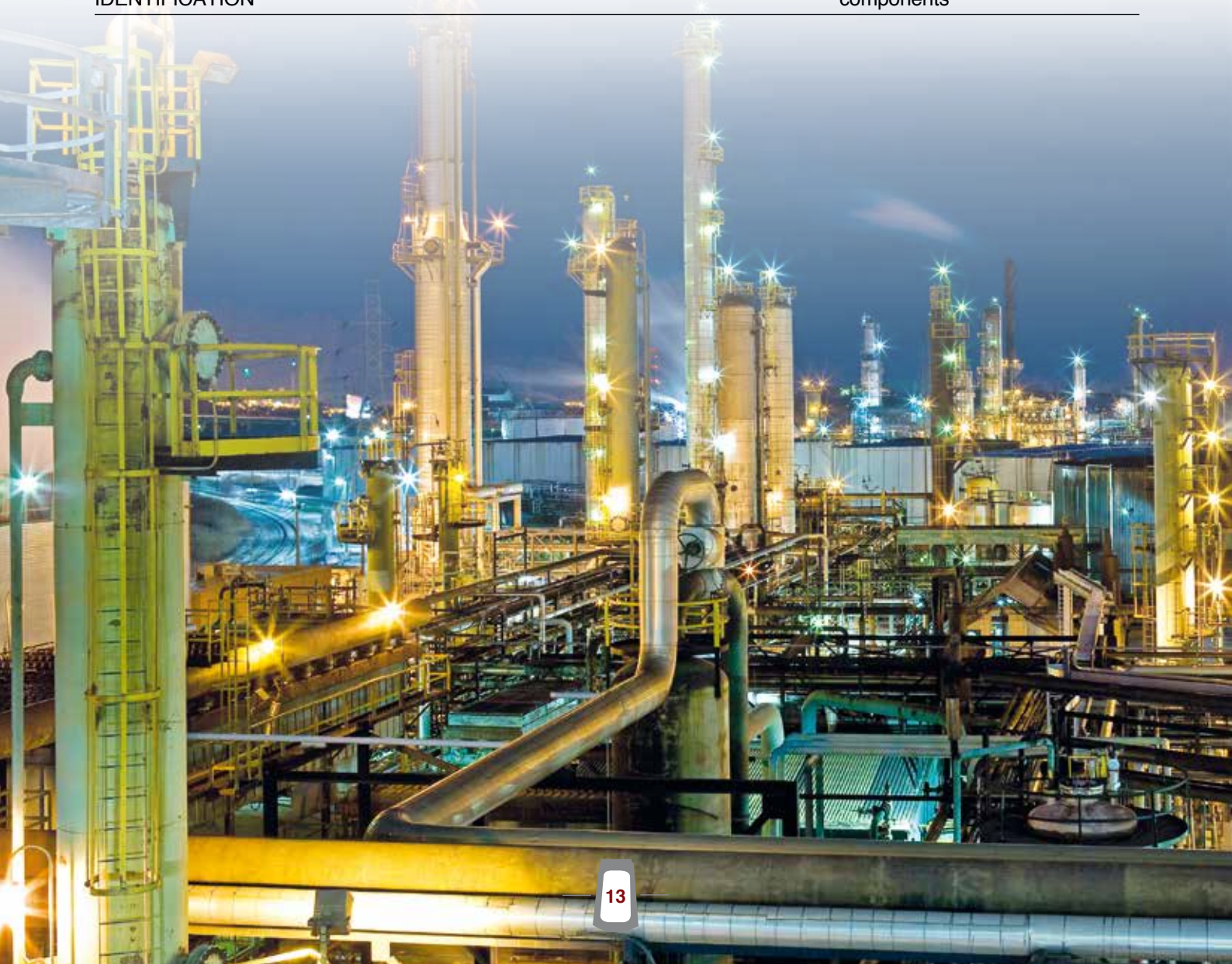



Applicable Standard-Specification

Lubricated Plug Valves are designed to use with most refining services according to API 599 or BS 5353 norms whichever is applicable.

API 6D norm aims to standardize the materials as well as instructions to manufacture valves suitable for energy transportation in the pipelines.

API 6D	Specification for Pipeline Valves.	BS 2080	Face to Face - Centre to Face - End to End - Steel Valves.
API 6FA	Specification for Fire Test for Valves.	BS 5353	Specification for Steel Plug Valves.
API RP6F	Recommended - Practice for Fire Test for Valves.	BS 6755 part 1	Testing of Valves (Spec. for Production Pressure Testing Requirements).
API 598	Valve Inspection and Testing.	BS 6755 part 2	Testing of valves (Spec. for Fire Safe Testing Requirements).
API 599	Steel Plug Valves Flanged or Butt Welding Ends.	CSA Z 245. 15	Canadian Standard Association.
ASME/ANSI B 16.5	Pipe Flanges and Flanged Fittings.	MSS-SP6	Standard Finish for contact Face of Pipe Flanges.
ASME/ANSI B 16.10	Face-to-Face and End-to-End Dimensions of Valves.	MSS-SP25	Standard Marking System for Valves.
ASME/ANSI B 16.25	Buttwelding Ends.	MSS-SP44	Steel Pipe Line Flanges.
ASME/ANSI B 16.34	Valves-Flanged, threaded and Welding Ends.	MSS-SP53	Quality Standard for Steel Casting-Magnetic Particle Examination Method.
ASME/ANSI B 31.3	Chemical Plant and Petroleum Refinery Piping.	MSS-SP54	Quality Standard for Steel Casting-Radiographic Examination Method.
ASME/ANSI B 31.4	Liquid Transportation System for Liquid Petroleum Gas.	MSS-SP55	Quality Standard for Steel Casting Visual Method.
ASME/ANSI B 31.8	Gas Transmission and Distribution Piping System.	MSS-SP61	Pressure Testing of Steel Valves.
ASME	Boiler and Pressure Vessel SECTION VIII - DIV.1 & 2	NACE Std. MR 01.75 Latest Edition	National Association of Corrosion Engineers.
ASME	Boiler and Pressure Vessel Section V.	ASTM	American Society for Testing and Materials.
ASNT-TC-1A	Recommended Practice for Personnel Qualification and Certification in Non destructive Testing.		





Pressure Test Tables in Accordance with API 598 & API 6D

ASME B16.34 Group Material 1.1

(A 105; A 216 WCB; A 350 LF2)

	Working Pressures by Classes, psig (Bar)					
	150 PN20	300 PN50	600 PN100	900 PN150	1500 PN250	2500 PN420
Working pressure rating	285 (20)	740 (51)	1480 (102)	2220 (153)	3705 (255)	6170 (425)
Hydraulic body test	450 (31)	1125 (78)	2225 (153)	3350 (231)	5575 (384)	9275 (640)
Hydraulic seat test	314 (22)	814 (56)	1628 (112)	2442 (168)	4076 (281)	6787 (468)

ASME B16.34 Group Material 1.2 and 2.8

(A 350 LF6; A 216 WCC; A 352 LCC; A182 F44/ F51; UNS S31803/S31254/S32750; A 351 Gr. CK3MCuN / CE8MN/ CD4MCu / CD3MWCuN)

	Working Pressures by Classes, psig (Bar)					
	150 PN20	300 PN50	600 PN100	900 PN150	1500 PN250	2500 PN420
Working pressure rating	290 (20)	750 (52)	1500 (103)	2250 (155)	3750 (259)	6250 (431)
Hydraulic body test	450 (31)	1125 (78)	2250 (155)	3375 (233)	5625 (388)	9375 (646)
Hydraulic seat test	319 (22)	825 (57)	1650 (114)	2475 (171)	4125 (284)	6875 (474)

ASME B16.34 Group Material 1.3

(A 352 LCB)

	Working Pressures by Classes, psig (Bar)					
	150 PN20	300 PN50	600 PN100	900 PN150	1500 PN250	2500 PN420
Working pressure rating	265 (18)	695 (48)	1390 (96)	2085 (144)	3470 (239)	5785 (399)
Hydraulic body test	400 (28)	1050 (72)	2100 (145)	3150 (217)	5225 (360)	8700 (600)
Hydraulic seat test	292 (20)	765 (53)	1529 (105)	2294 (158)	3817 (263)	6364 (439)

ASME B16.34 Group Material 2.1 and 2.2

(A 182 F304; A 479 Gr. 304; A 351 CF3; A 351 CF8; A 182 F316; A 479 Gr. 316; A 351 CF3M)

	Working Pressures by Classes, psig (Bar)					
	150 PN20	300 PN50	600 PN100	900 PN150	1500 PN250	2500 PN420
Working pressure rating	275 (19)	720 (50)	1440 (99)	2160 (149)	3600 (248)	6000 (414)
Hydraulic body test	425 (29)	1100 (76)	2175 (150)	3250 (224)	5400 (372)	9000 (621)
Hydraulic seat test	303 (21)	792 (55)	1584 (109)	2376 (164)	3960 (273)	6600 (455)

ASME B16.34 Group Material 2.3

(A 182 F304/F316L; A 479 Gr. 304/316L)

	Working Pressures by Classes, psig (Bar)					
	150 PN20	300 PN50	600 PN100	900 PN150	1500 PN250	2500 PN420
Working pressure rating	230 (16)	600 (41)	1200 (83)	1800 (124)	3000 (207)	5000 (345)
Hydraulic body test	350 (24)	900 (62)	1800 (124)	2700 (186)	4500 (310)	7500 (517)
Hydraulic seat test	253 (17)	660 (46)	1320 (91)	1980 (137)	3300 (228)	5500 (379)

Hydraulic Pressure Test Duration In accordance with API 6D and API 598

Valve Size		Test Duration		Valve Size		Test Duration	
DN (mm)	NPS (Inches)	Shell	Seat (1)	DN (mm)	NPS (Inches)	Shell	Seat (1)
API 598							
15 - 50	1/2 - 2	15 sec.	15 sec.	15 - 100	1/2 - 4	2 min.	2 min.
65 - 150	2 1/2 - 6	60 sec.	60 sec.	150 - 250	6 - 10	5 min.	5 min.
200 - 300	8 - 12	120 sec.	120 sec.	300 - 450	12 - 18	15 min.	5 min.
350 and over	14 and over	300 sec.	120 sec.	500 and over	20 and over	30 min.	5 min.
API 6D / ISO 14313							

(1) Duration applicable also for the pneumatic seat test (5.5 bar/80 psi).



ANSI Class 150 (PN 20)

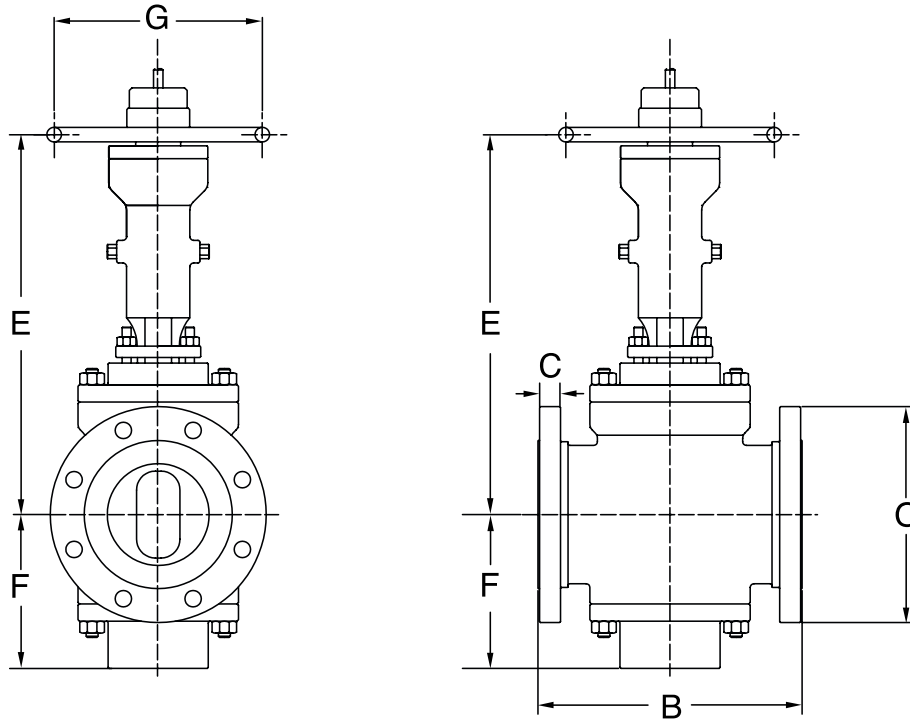

Handwheel Operated

Size	NPS DN	2"	3"	4"	6"	8"
Face To Face						
RF	B	178	203	229	267	292
RTJ	B	191	216	241	279	305
BW	B	267	330	356	457	521
Flange Diameter	O	152	191	229	279	343
Flange Thickness	C	16	19	24	26	29
Top of Handwheel to center Line of valve	E	306	350	390	450	595
Body Cap to Center Line of valve	F	130	150	170	225	25
Handwheel Diameter	G	270	270	270	350	500
Weight RF/RTJ	Kg	30	37	45	91	182
Weight BW	Kg	27	32	38	80	150
Minimum space required to remove Slips.	H	80	85	120	210	260

NOTES: Face to Face in accordance with API6D or ASME B16.10
 Handwheel Dimension (G) are indicative only.
 The weights are indicative only.



ANSI Class 150 (PN 20)

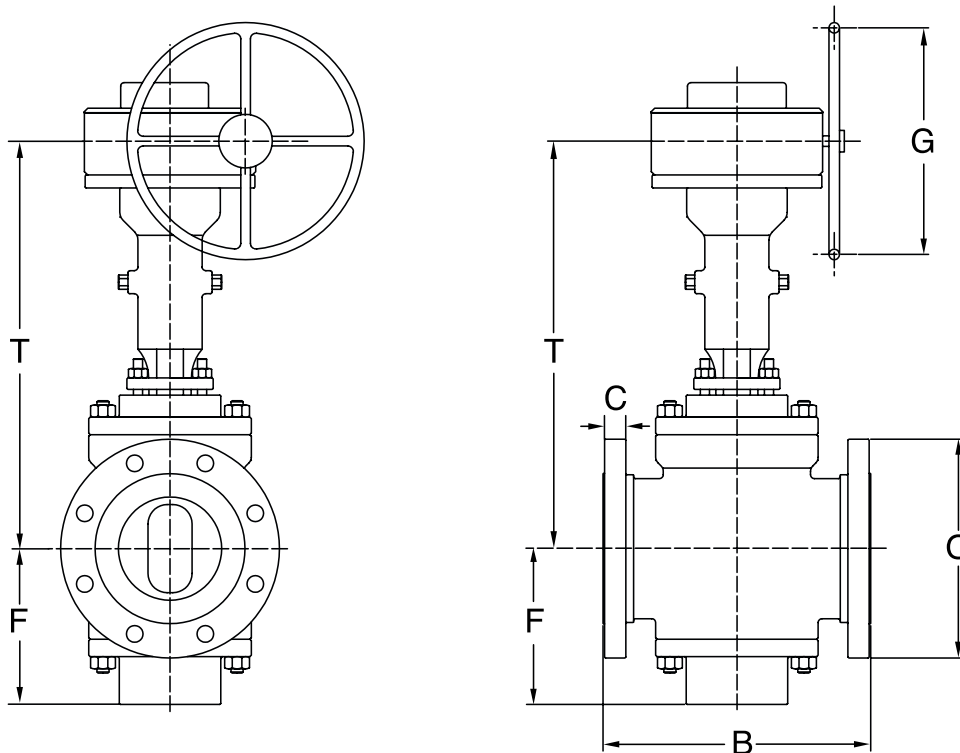

Gear Operated

Size	NPS DN	10"	12"	14"	16"	18"	20"	24"	28"	30"	36"
Face To Face											
RF	B	533	610	686	762	864	914	1067	1244	1295	1600
RTJ	B	546	622	699	775	876	927	1080	1257	1308	1537
BW	B	559	635	686	762	864	914	1067	1244	1295	1600
Flange Diameter	O	406	483	533	597	635	699	813	927	984	1168
Flange Thickness	C	30	32	35	37	40	43	48	52	54	60
Center line of valve To center line of hanwheel	T	290	345	380	420	460	530	570	720	830	870
Body Cap to Center Line	F	650	820	850	990	990	1020	1100	1550	1650	1960
Handwheel Diameter	G	500	500	500	500	500	500	700	700	700	800
Weight RF/RTJ	Kg	240	370	460	620	700	1250	1800	5900	6400	7500
Weight BW	Kg	220	330	405	550	616	1100	1600	5200	5600	6600
Minimum space required to remove Slips.	H	385	470	490	550	590	650	730	840	1050	1510

NOTES: Face to Face according to API 6D/ASME B16.10 (DN 28" according to API 6D ASME/ANSI 300)
 Flange Dimensions of NPS DN 28" 30 "36" are in accordance with ASME B16.47
 Handwheel Dimension (G) is indicative only.
 The weights indicated are indicative only.



ANSI Class 300 (PN 50)

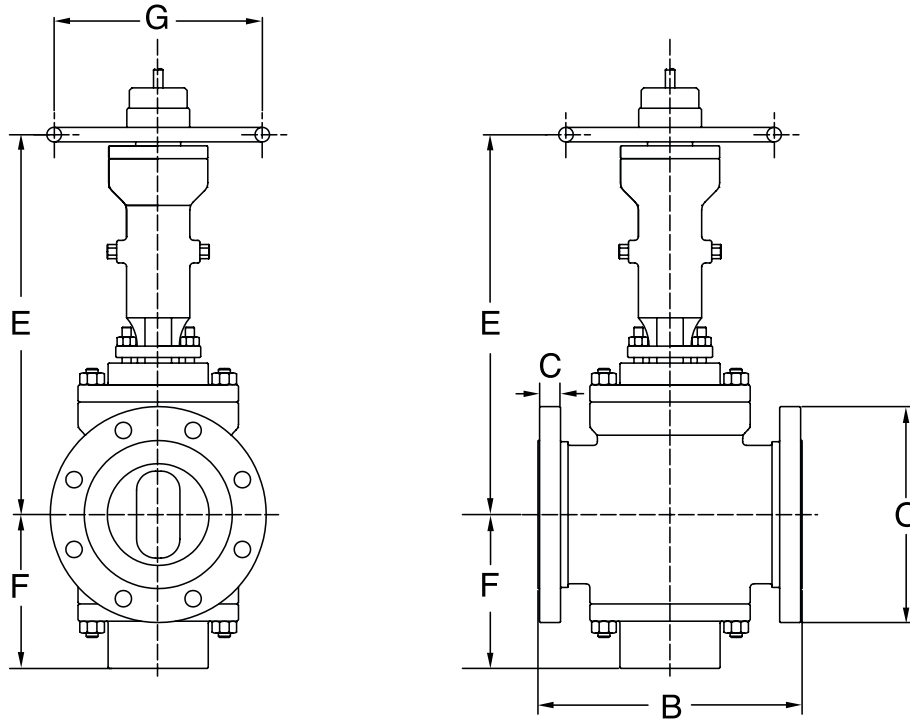

Handwheel Operated

Size	NPS DN	2"	3"	4"	6"
Face To Face					
RF	B	216	283	305	403
RTJ	B	232	298	321	419
BW	B	267	330	356	457
Flange Diameter	O	165	210	254	318
Flange Thickness	C	22	29	32	37
Center line of valve To center line of hanwheel	E	310	330	390	550
Body Cap to Center Line of valve	F	130	150	170	225
Handwheel Diameter	G	270	270	350	350
Weight RF/RTJ	Kg	32	44	70	100
Weight BW	Kg	28	39	62	80
Minimum space required to remove Slips.	H	80	85	120	210

NOTES: Face to Face in accordance with API6D/ASME B16.10
Handwheel Dimension (G) are indicative only.
The weights are indicative only.



ANSI Class 300 (PN 50)

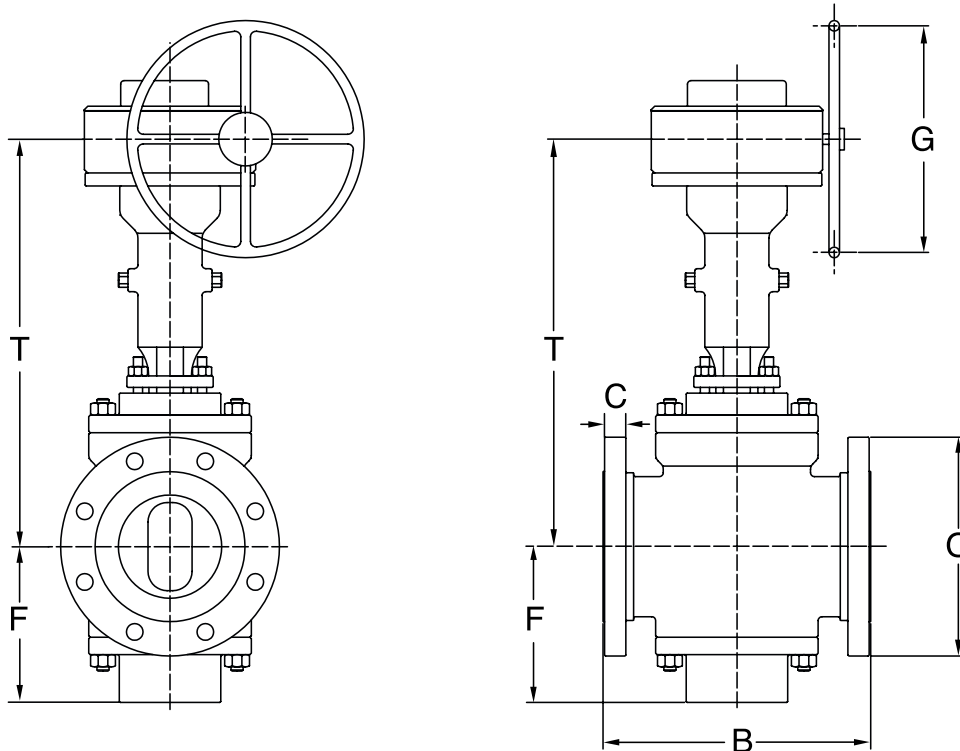

Gear Operated

Size	NPS DN	6"	8"	10"	12"	14"	16"	18"	20"	24"	28"	30"	36"
Face To Face													
RF	B	403	419	457	502	762	838	914	991	1143	1346	1397	1727
RTJ	B	419	435	584	518	778	854	930	1010	1165	1372	1422	1756
BW	B	457	521	559	635	762	838	914	991	1321	1346	1397	1727
Flange Diameter	O	318	381	445	520	585	650	710	775	915	1035	1090	1270
Flange Thickness	C	37	42	48	51	54	58	61	64	70	86	95	111
Center line of valve To center line of hanwheel	T	550	691	750	940	940	940	1040	1240	1302	1805	1805	2320
Body Cap to Center Line of valve	F	220	240	320	380	400	425	530	650	670	750	830	880
Handwheel Diameter	G	350	500	500	500	500	500	500	500	700	700	700	800
Weight RF/RTJ	Kg	120	180	430	670	950	1300	1650	1930	3730	5850	6720	10750
Weight BW	Kg	80	165	240	590	840	1145	1450	1698	3290	5150	5920	9470
Minimum space required to remove Slips.	H	260	360	385	470	490	550	590	650	730	840	1050	1510

NOTES: Face to Face in accordance with API6D/ASME B16.10
 Flange Dimensions of NPS DN 28"/30"/36" in accordance with ASME B16.47
 Handwheel Dimensions (G) are indicative only.
 The weights are indicative only.



ANSI Class 600 (PN 100)

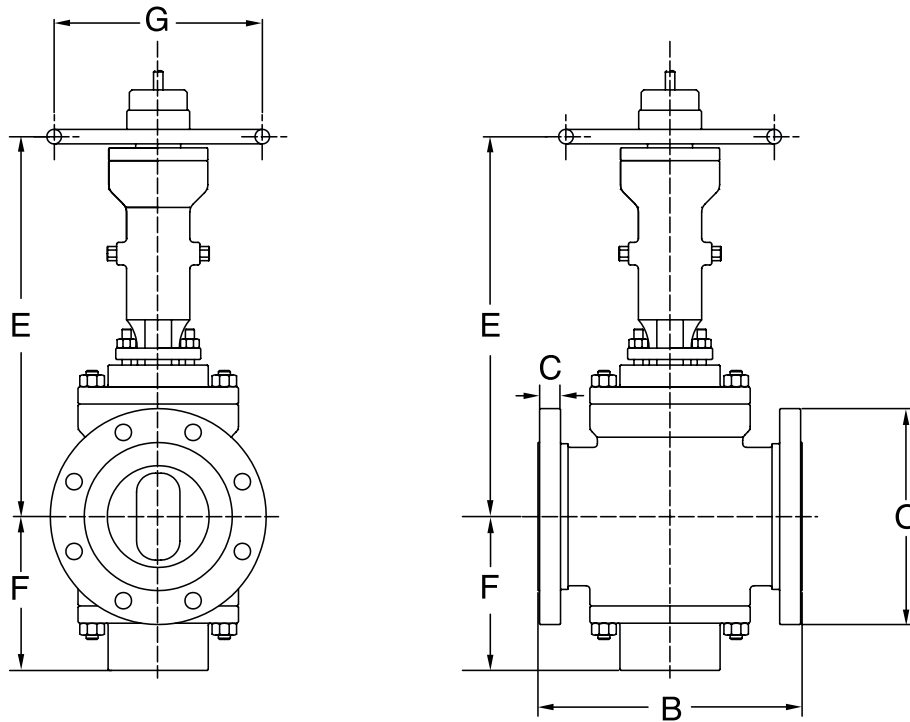

Handwheel Operated

Size	NPS DN	2"	3"	4"
Face To Face				
RF	B	292	356	432
RTJ	B	295	359	435
BW	B	292	356	432
Flange Diameter	O	165	210	273
Flange Thickness	C	26	32	38
Center line of valve To center line of hanwheel	E	306	350	390
Body Cap to Center Line of valve	F	130	150	170
Handwheel Diameter	G	270	270	270
Weight RF/RTJ	Kg	54	65	115
Weight BW	Kg	42	53	80
Minimum space required to remove Slips.	H	80	85	120

NOTES: Face to Face according to API 6D
Handwheel Dimension (G) is indicative only.
The weights indicated are indicative only.



ANSI Class 600 (PN 100)

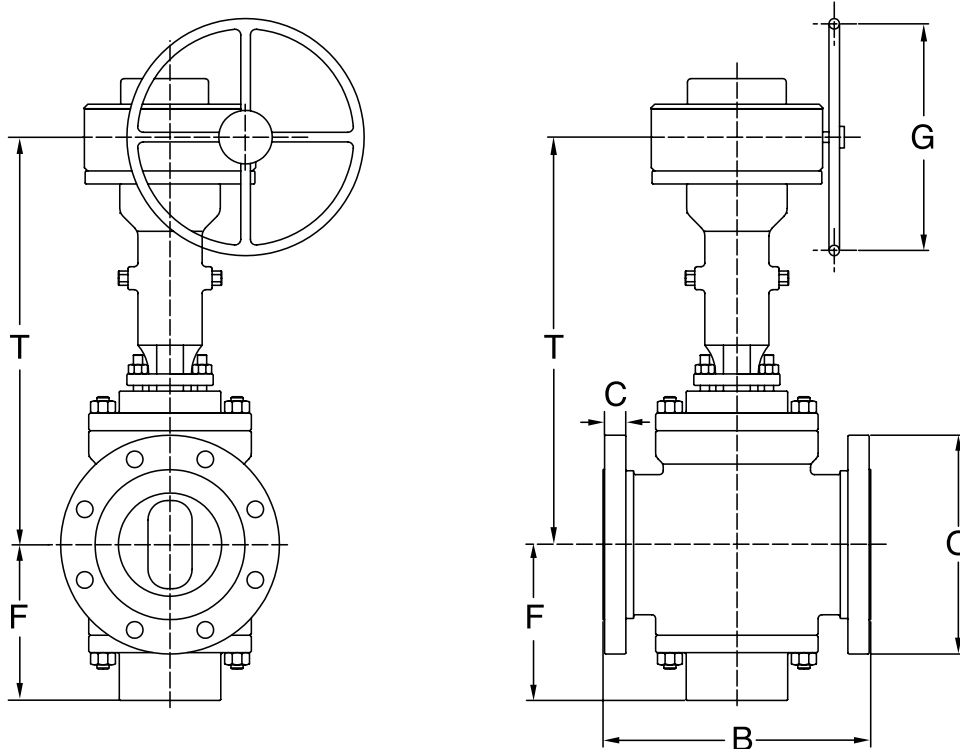

Gear Operated

Size	NPS DN	2"	3"	4"	6"	8"	10"	12"	14"	16"	18"	20"	24"
Face To Face													
RF	B	292	356	432	559	660	787	838	889	991	1092	1194	1397
RTJ	B	295	359	435	562	664	791	841	892	994	1095	1200	1407
BW	B	292	356	432	559	660	787	838	889	991	1092	1194	1397
Flange Diameter	O	165	210	273	356	419	508	559	603	686	743	813	940
Flange Thickness	C	26	32	38	48	56	64	67	70	77	83	89	102
Center line of valve To center line of hanwheel	T	395	395	510	665	695	950	985	1205	1205	1630	1690	1860
Body Cap to Center Line of valve	F	145	145	195	240	290	415	450	510	510	575	610	685
Handwheel Diameter	G	260	260	360	550	550	550	550	800	800	800	800	800
Weight RF/RTJ	Kg	56	68	125	320	510	910	1160	1880	1970	2960	3750	6010
Weight BW	Kg	44	55	85	221	373	746	940	1492	1672	2520	3050	4840
Minimum space required to remove Slips.	H	80	85	120	210	360	385	470	490	550	590	650	730

NOTES: Face to Face according to API 6D
Handwheel Dimension (G) is indicative only.
The weights indicated are indicative only.



ANSI Class 900 (PN 150)

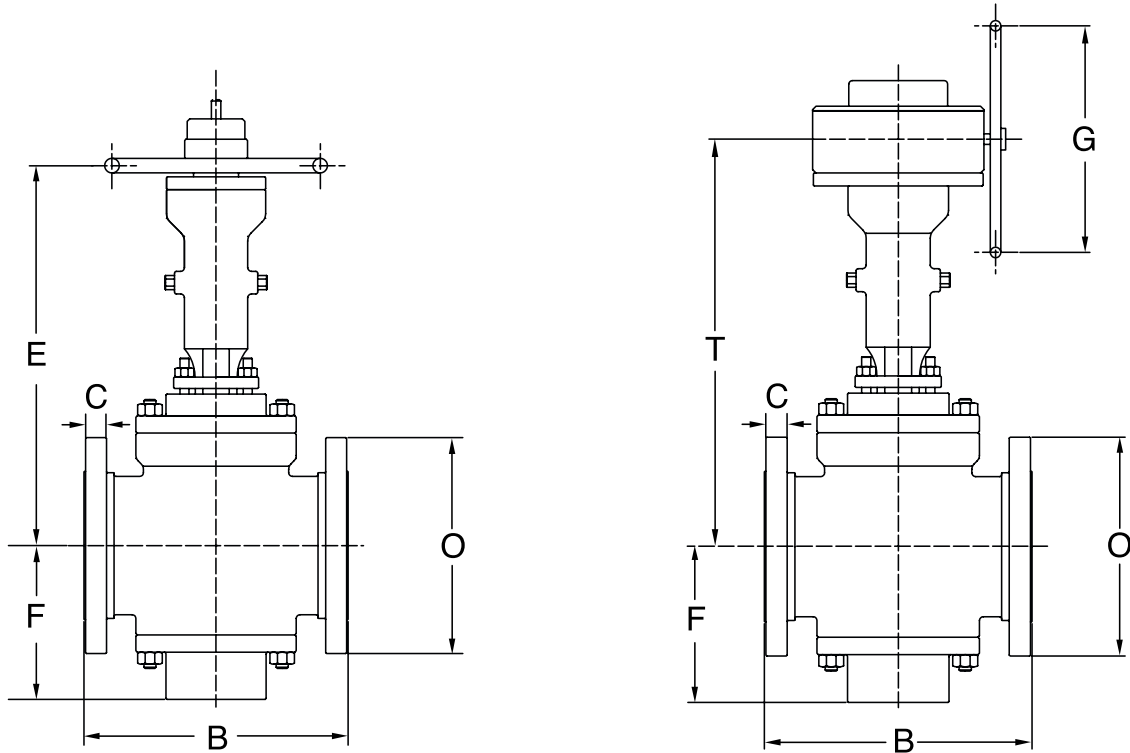

Size	NPS DN	Handwheel Operated			Gear Operated		
		2"	3"	4"	6"	8"	10"
Face To Face							
RF	B	368	381	457	610	737	838
RTJ	B	371	384	460	613	740	841
BW	B	368	381	457	610	737	838
Flange Diameter	O	216	242	292	381	470	546
Flange Thickness	C	38	38	45	56	64	70
Center line of valve To center line of hanwheel	T	493	493	510	670	950	1315
Body Cap to Center Line	F	185	215	270	305	430	560
Handwheel Diameter	G	350	350	550	550	800	800
Weight RF/RTJ	Kg	85	135	185	455	660	1650
Weight BW	Kg	62	95	163	370	515	1285
Minimum space required to remove Slips.	H	80	85	120	210	360	385

NOTES: The weights indicated are indicative only.
Handwheel Dimension (G) are indicative only.



ANSI Class 1500 (PN 250)

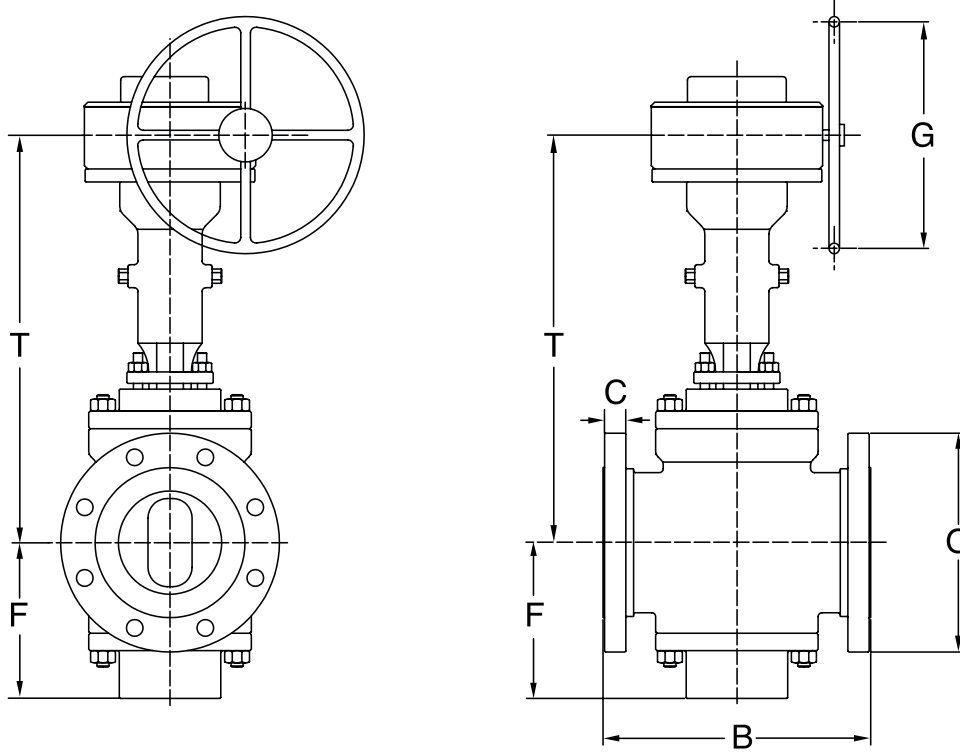

Size	NPS DN	Handwheel Operated			Gear Operated		
		2"	3"	4"	6"	8"	10"
Face To Face							
RF	B	368	470	546	705	832	991
RTJ	B	371	473	549	711	841	1000
BW	B	368	470	546	705	832	991
Flange Diameter	O	216	267	311	394	483	584
Flange Thickness	C	38	48	54	83	92	108
Center line of valve To center line of hanwheel	T	860	890	935	985	1035	1220
Body Cap to Center Line	F	185	200	297	325	390	480
Handwheel Diameter	G	350	350	550	550	800	800
Weight RF/RTJ	Kg	85	135	220	395	760	1230
Weight BW	Kg	62	95	194	321	592	960
Minimum space required to remove Slips.	H	80	85	120	210	360	385

NOTES: The weights indicated are indicative only.
Handwheel Dimension (G) are indicative only.



Quality Assurance System

After 95 years of manufacturing experience and latest technology, **Galli&Cassina** Quality Assurance System has been assessed, approved and certified against the following quality assurance standards: ISO 9001-and API Q1.

Rigorous procedures and internal audits ensure that the Quality System is implemented at all stages: incoming materials, production, inspection, assembly, final test, packing and shipping. Every product is designed and



manufactured to comply with the latest applicable standards.

Quality Assurance Development

Galli&Cassina's Quality Assurance System ISO 9001-2008 - HSE ISO 14001 & ISO 18001 have been assessed, approved and certified by Lloyd's Register, while the API 6D and API 6A monograms have been certified by API (American Petroleum Institute): all the certificates are the result of **Galli&Cassina's** dedication towards the aim of good reputation in the world-wide valve market, since 95 years.

In addition **Galli&Cassina** Plug Valves are in compliance with CE Pressure Equipment Directive PED N. 97/23/EC and ATEX (N. 94/9/EC) for products intended for use in potentially explosive atmospheres.



Customer Service

Galli&Cassina's Customer Service is always willing to assist the customer with a prompt response to "service" requests.

Full after sales services assistance can be offered either at our workshop or on site, spare parts supply. Training programs, on operation and safety.

**Cina - UAE - Kuwait
Saudi Arabia - Europe
India - U.S.A - Canada
Venezuela - Colombia
Brasil.**





Conversion Tables

To Convert	Into	Multipl y
A		
Atmosphere	bar	1.01325
Atmosphere	cms. of mercury	76.0
Atmosphere	ft. of water (at 4°C)	33.90
Atmosphere	in. of mercury (at 0°C)	29.92
Atmosphere	kgs./sq. cm.	1.0333
Atmosphere	pounds/sq. in.	14.70
Atmosphere	pascal (N/m ²)	98070

B		
Bar	atmosphere	1.0197
Bar	psi	14.505
Bar	pascal	105
Barrels(U.S.,liquid)	gallons	31.5
Barrels (oil)	gallons (oil)	42.0
Barrels (42 gal.)	cubic. meter	0.159
Barrels/hr	liter/second	0.044
Btu	foot-lbs.	778.3
Btu	gram-calories	252.0
Btu	horsepower-hrs.	3.931 x 10-4
Btu/hr	kilowatt-hrs	2.928 x 10-4
Btu/hr	horsepower	3.931 x 10-4
Btu	Watts	0.2931

C		
Calories, gram (mean)	B.T.U. (mean)	3.9685 x 10-3
Centigrade	Fahrenheit	(C° 9/5)+32
Centimeters	feet	3.281 x 10-2
Centimeters	inches	0.3937
Centimeters	mils	393.7
Centimeters of mercury	atmospheres	0.01316
Centimeters of mercury	feet of water	0.4461
Centimeters of mercury	pounds/sq. in.	0.1934
Circumference	radians	6.283
Cubic centimeters	cu. feet	3.531 x 10-5
Cubic centimeters	cu. inches	0.06102
Cubic centimeters	gallons (U.S. liq.)	2.642 x 10-4
Cubic feet	cu. cms.	28.320.0
Cubic feet	cu. inches	1.728.0
Cubic feet	gallons (U.S. liq.)	7.481
Cubic feet	liters	28.32
Cubic feet/hour	cubic meters/hour	0.02832
Cubic feet/min.	gallons/sec.	0.1247
Cubic feet/min.	cubic meters/hour	1.6990
Cubic inches	cu. cms.	16.39
Cubic inches	gallons	4.329 x 10-3
Cubic inches	quarts (U.S. liq.)	0.01732
Cubic meters	cu. feet	35.31
Cubic meters	gallons (U.S. liq.)	264.2
Cubic meters/hour	cu. feet/min	0.5886
Cubic meters/hour	cu. feet/hour	35.315
Cubic meters/hour	gallons /hour	264.17

D		
Degres (angle)	radians	0.01745
Drams		
(apothecaries' or troy)	ounces (avoirdupois)	0.13714
Drams		
(apothecaries' or troy)	ounces (troy)	0.125
Drams		
(U.S., fluid or apoth)	cubic cm.	3.6967
Drams	grams	1.772
Drams	grains	27.3437
Drams	ounces	0.0625

F		
Fahrenheit	centigrade	(F 32°) 5/9
Feet	centimeters	30.48
Feet	kilometers	3.048 x 10-4
Feet	meters	0.3048
Feet	miles (naut.)	1.645 x 10-4
Feet	miles (stat.)	1.894 x 10-4
Feet of water	atmospheres	0.02950
Feet of water	in. of mercury	0.8826
Feet of water	kgs./sq. cm.	0.03045
Feet of water	kgs./sq. meter	304.8
Feet of water	pounds/sq.ft.	62.43
Feet of water	pounds/sq.in	0.4335
Foot-pounds	Btu	1.286 x 10-3
Foot-pounds	gram-calories	0.3238

To Convert	Into	Multipl y
F		
Foot-pounds	hp.-hrs.	5.050 x 10-7
Foot-pounds	kilowatt-hrs.	3.766 x 10-7
Foot-pounds/min.	Btu/min.	1.286 x 10-3
Foot-pounds/min.	horsepower	3.030 x 10-5
Foot-pounds/sec.	Btu/hr.	4.6263
Foot/square	Foot/meter	0.093
Foot/cubic/minute	liter/second	0.471
Furlongs	miles (U.S.)	0.125
Furlongs	feet	660.0

G		
Gallons	cu.cms	3.785.0
Gallons	cu.feet	0.1337
Gallons	cu.inches	231.0
Gallons	cu.meters	3.785 x 10-3
Gallons	cu.yards	4.951 x 10-3
Gallons	liters	3.785
Gallons (liq. Br Imp.)	gallons (U.S. liq.)	1.20095
Gallons (U.S.)	gallons (Imp.)	0.83267
Gallons of water	pounds of water	8.3453
Gallons/min.	cu.ft./sec.	2.228 x 10-3
Gallons/min.	liters/sec.	0.06308
Gallons/min.	cu.ft./hr.	8.0208
Grains (troy)	grain (avdp.)	1.0
Grains (troy)	grams	0.06480
Grains (troy)	ounces (avdp.)	2.286 x 10-3
Grains (troy)	pennyweight (troy)	0.04167
Grains /U.S. gal.	parts/million	17.118
Grains /U.S. gal.	pounds/million gal.	142.86
Grains /Imp. gal.	parts/million gal.	14.286
Grams	grains	15.43
Grams	ounces (avdp.)	0.03527
Grams	ounces (troy)	0.03215
Grams	poundals	0.07093
Grams	pounds	2.205 x 10-3
Gram/liter	parts/million	1.000.0
Gram-calories	Btu	3.9683 x 10-3
Gram-calories	foot-pounds	3.0880
Gram-calories	kilowatt-hrs.	1.1630 x 10-6
Gram-calories	watt-hrs.	1.1630 x 10-3

H		
Horsepower	Btu/min.	42.40
Horsepower	foot-lbs./min.	33.000
Horsepower	foot-lbs./sec.	550.0
Horsepower (metric)	horsepower	0.9863
542.5 ft. lb/sec.)	(550.5 ft. lb/sec.)	
Horsepower	horsepower (metric)	1.014
(550.5 ft. lb/sec.)	(542.5 ft. lb/sec.)	
Horsepower	kilowatts	0.7457
Horsepower	watts	745.7
Horsepower (boiler)	Btu/hr	33.520
Horsepower (boiler)	kilowatts	9.803
Horsepower-hrs.	Btu	2.547
Horsepower-hrs.	foot-lbs.	1.98 x 10 ⁶
Horsepower-hrs.	kilowatts-hrs.	0.7457

I		
Inches	pounds	0.113
Inches	centimeters	2.540
Inches	meters	2.540 x 10-2
Inches	millimeters	25.40
Inches of mercury	kilopascal	3.376
Inches of mercury	atmospheres	0.03342
Inches of mercury	feet of water	1.133
Inches of mercury	kgs./sq. cm.	0.03453
Inches of mercury	kgs./sq. meter	345.3
Inches of mercury	pounds/sq. ft.	70.73
Inches of mercury	pounds/sq. in.	0.4912
Inches of water (at 4°C)	kilopascal	0.248
Inches of water (at 4°C)	atmospheres	2.458 x 10-3
Inches of water (at 4°C)	inches of mercury	0.07355
Inches of water (at 4°C)	kgs./sq. cm.	2.538 x 10-3
Inches of water (at 4°C)	pounds/sq. ft.	5.204
Inches of water (at 4°C)	pounds/sq. in.	0.03613

J		
Joules	Btu	9.480 x 10-4



Conversion Tables

To Convert	Into	Multipli by
K		
Kilograms	grams	1.000.0
Kilograms	pounds	2.205
Kilograms/cu. meter	pounds/cu. ft.	0.06243
Kilograms/cu. meter	pounds/cu. in.	3.613 x 10 ⁻⁵
Kilograms/sq. cm	atmosphere	0.9678
Kilograms/sq. cm	feet of water	32.84
Kilograms/sq. cm	inches of mercury	28.96
Kilograms/sq. cm.	pounds/sq. ft.	2.048
Kilograms/sq. cm.	pounds/sq. in.	14.22
Kilograms/sq. meter	atmosphere	9.678 x 10 ⁻⁵
Kilograms/sq. meter	feet of water	3.281 x 10 ⁻³
Kilograms/sq. meter	inches of mercury	2.896 x 10 ⁻³
Kilograms/sq. meter	pounds/sq. ft.	0.2048
Kilograms/sq. meter	pounds/sq. in.	1.422 x 10 ⁻³
Kilograms/sq. mm.	kgs./sq. meter	106
Kilograms-calories	Btu	3.968
Kilograms-calories	foot-pounds	3.088
Kilograms-calories	hp-hrs	1.560 x 10 ⁻³
Kilograms-calories	kilowatt-hrs	1.163 x 10 ⁻³
Kilograms meters	Btu	9.294 x 10 ⁻³
Kilometers	centimeters	105
Kilometers	feet	3.281
Kilometers	miles	0.6214
kilowatts	Btu/min.	56.87
kilowatts	foot-lbs./min.	4.426 x 10 ⁴
kilopascal	Bar	0.01
kilopascal	Pounds/sq.in	0.145
kilowatts	horsepower	1.341
kilowatts-hrs.	Btu	3.413
kilowatts-hrs.	foot-lbs.	2.655 x 10 ⁶
kilowatts-hrs.	horsepower-hrs.	1.341
knots	statute miles/hr.	1.151

To Convert	Into	Multipli by
L		
Liters	cu. cm.	1.000.0
Liters	cu. feet	0.03531
Liters	cu. inches	61.02
Liters	gallons (U.S. liq.)	0.2642

To Convert	Into	Multipli by
M		
MMSCFD	cubic meter/second	0.328
Meters	centimeters	100.0
Meters	feet	3.281
Meters	inches	39.37
Meters	millimeters	1.000.0
Meters	yards	1.094
Microns	inches	39.37 x 10 ⁻⁶
Microns	meters	1 x 10 ⁻⁶
Miles (statute)	feet	5.280
Miles (statute)	kilometers	1.609
Miles/hr.	cms./sec.	44.70
Miles/hr.	feet/min.	88.0
Miils	inches	0.001
Miils	yards	2.778 x 10 ⁻⁵

To Convert	Into	Multipli by
N		
Nepers	decibels	8.686

To Convert	Into	Multipli by
O		
Ohms	megohms	10 ⁻⁶
Ohms	microhms	10 ⁶
Ounces (avoirdupois)	drams	16.0
Ounces (avoirdupois)	grains	437.5
Ounces (avoirdupois)	grams	28.35
Ounces (avoirdupois)	pounds	0.0625
Ounces (avoirdupois)	ounces (troy)	0.9115
Ounces (troy)	grains	480.0
Ounces (troy)	grams	31.10
Ounces (troy)	ounces (avdp.)	1.09714
Ounces (troy)	pounds (troy)	0.08333

To Convert	Into	Multipli by
P		
Pound/sq in.	kilopascal	6.894
Pound/sq in.	bar	0.06894
Pound/sq in.	pascal	6894.14
Pound/sq in.	pounds/sq foot	144
Pascal (N/m ²)	bar	10 ⁻⁵

To Convert	Into	Multipli by
P		
Pascal (N/m ²)	pound/sq in.	0.145 x 10 ⁻³
Pascal (N/m ²)	atmosphere	1.0197 x 10 ⁻⁵
Pounds (avoirdupois)	drams	256.
Pounds (avoirdupois)	grains	7.000
Pounds (avoirdupois)	grams	28.35
Pounds (avoirdupois)	kilograms	0.02835
Pounds (avoirdupois)	ounces	16.0
Pounds/gallon	kg/liter	0.119
Pounds of water	cu. feet	0.01602
Pounds of water	cu. inches	27.68
Pounds of water	gallons	0.1198
Pounds of water/min.	cu. ft./sec.	2.670 x 10 ⁻⁴
Pounds/cu. ft.	grams/cu. cm.	0.01602
Pounds/cu. ft.	kgs./cu. meter	16.02
Pounds/cu. ft.	pounds/cu. in.	5.787 x 10 ⁻⁴
Pounds/cu. in.	pounds/cu. ft.	1.728
Pounds/sq. ft.	atmospheres	4.725 x 10 ⁻⁴
Pounds/sq. ft.	feet of water	0.01602
Pounds/sq. ft.	inches of mercury	0.014414
Pounds/hr.	kg/hr	0.453
Pounds/sq. in.	atmospheres	0.06804
Pounds/sq. in.	feet of water	2.307
Pounds/sq. in.	inches of mercury	2.036
Pounds/sq. in.	kgs./sq. meter	703.1
Pounds/sq. in.	pounds/sq. ft.	144.0

To Convert	Into	Multipli by
R		
Radians	degrees	57.30
Revolution/min.	degrees/sec.	6.0
Revolution/min.	radians/sec.	0.1047
Revolution/min.	rev./sec.	0.01667

To Convert	Into	Multipli by
S		
Square centimeters	sq. feet	1.076 x 10 ⁻³
Square centimeters	sq. inches	0.1550
Square centimeters	sq. meters	0.0001
Square centimeters	sq. millimeters	100.0
Square feet	acres	2.296 x 10 ⁻⁵
Square feet	sq. cms.	929.0
Square feet	sq. inches	144.0
Square feet	sq. miles	3.587 x 10 ⁻⁸
Square inches	sq. cms.	6.452
Square inches	sq. feet	6.944 x 10 ⁻³
Square inches	sq. yards	7.716 x 10 ⁻⁴
Square meters	sq. feet	10.76
Square meters	sq. inches	1.550
Square meters	sq. millimeters	106
Square meters	sq. yards	1.196
Square millimeters	sq. inches	1.550 x 10 ⁻³
Square yards	sq. feet	9.0
Square yards	sq. inches	1.296
Square yards	sq. meters	0.8361

To Convert	Into	Multipli by
T		
Temperature (°C) + 273	absolute temperature (°C)	1.0
Temperature (°C) + 17.78	temperature (°F)	1.8
Temperature (°F) + 460	absolute temperature (°F)	1.0
Temperature (°F) - 32°	temperature (°C)	5/9
Tons (metric)	kilograms	1000
Tons (metric)	pounds	2.205
Tons of water/24hrs	pounds of water	83.333
Tons of water/24hrs	gallons/min.	0.16643
Tons of water/24hrs	cu. ft./hr.	1.3349

To Convert	Into	Multipli by
W		
Watts	Btu/hr.	3.4129
Watts	Btu/min.	0.05688
Watts	horsepower	1.341 x 10 ⁻³
Watts	horsepower (metric)	1.360 x 10 ⁻³
Watts	kilowatts	0.001
Watts	B.T.U. (mean)/min.	0.056884
Watts	Btu	3.413
Watts	horsepower-hrs.	1.341 x 10 ⁻³

To Convert	Into	Multipli by
Y		
Yards	centimeters	91.44
Yards	kilometers	9.144 x 10 ⁻⁴
Yards	meters	0.9144



Temperature Conversion Table

$$^{\circ}\text{C} = \frac{5}{9} (^{\circ}\text{F} - 32)$$

$$^{\circ}\text{F} = \frac{9}{5} ^{\circ}\text{C} + 32$$

$^{\circ}\text{C}$		$^{\circ}\text{F}$	$^{\circ}\text{C}$		$^{\circ}\text{F}$
-273.0	-459.4		43.3	110	230.0
-268.0	-450		46.1	115	239.0
-240.0	-400		48.9	120	248.0
-212.0	-350		54.4	130	266.0
-184.0	-300		60.0	140	284.0
-157.0	-250	-418.0	65.6	150	302.0
-129.0	-200	-328.0	71.1	160	320.0
-101.0	-150	-238.0	76.7	170	338.0
- 73.0	-100	-148.0	82.2	180	356.0
- 45.6	- 50	- 58.0	87.8	190	374.0
- 42.8	- 45	- 49.0	93.3	200	392.0
- 40.0	- 40	- 40.0	98.9	210	410.0
- 37.2	- 35	- 31.0	104.4	220	428.0
- 34.4	- 30	22.0	110.0	230	446.0
- 31.7	- 25	- 13.0	115.6	240	464.0
- 28.9	- 20	- 4.0	121.0	250	482.0
- 26.1	- 15	5.0	149.0	300	572.0
- 23.2	- 10	14.0	177.0	350	662.0
- 20.6	- 5	23.0	204.0	400	752.0
- 17.8	0	32.0	232.0	450	842.0
- 15.0	5	41.0	260.0	500	932.0
- 12.2	10	50.0	288.0	550	1022.0
- 9.4	15	59.0	316.0	600	1112.0
- 6.7	20	68.0	343.0	650	1202.0
- 3.9	25	77.0	371.0	700	1292.0
- 1.1	30	86.0	399.0	750	1382.0
0	32	89.6	427.0	800	1472.0
7.7	35	95.0	454.0	850	1562.0
4.4	40	104.0	482.0	900	1652.0
7.2	45	113.0	510.0	950	1742.0
10.0	50	122.0	538.0	1000	1832.0
12.8	55	131.0	566.0	1050	1922.0
15.6	60	140.0	593.0	1100	2012.0
18.3	65	149.0	621.0	1150	2102.0
21.1	70	158.0	649.0	1200	2192.0
23.9	75	167.0	677.0	1250	2282.0
26.7	80	176.0	704.0	1300	2372.0
29.4	85	185.0	732.0	1350	2462.0
32.2	90	194.0	762.0	1400	2552.0
35.0	95	203.0	788.0	1450	2642.0
37.8	100	212.0	816.0	1500	2732.0
40.6	105	221.0			

NOTES: The temperature to be converted is the figure in the yellow column.
To obtain a reading in $^{\circ}\text{C}$ use left column; for conversion to $^{\circ}\text{F}$ use the right column.



Pressure/Temperature Rating According to ASME B16.34-2013

Material: ASTM A 105, ASTM A 216 Gr. WCB, ASTM A 350 Gr. LF2 (Table 2-1.1)

Temperature	Working Pressures by Classes, psig (Bar)					
°F (°C)	150	300	600	900	1500	2500
-20 to 10 (-29 to 38)	285 (20)	740 (51)	1.480 (102)	2.220 (153)	3.705 (255)	6.170 (425)
200 (93)	260 (18)	680 (47)	1.360 (94)	2.035 (140)	3.395 (234)	5.655 (390)
300 (149)	230 (16)	655 (45)	1.310 (90)	1.965 (135)	3.270 (225)	5.450 (376)
400 (204)	200 (14)	635 (44)	1.265 (87)	1.900 (131)	3.170 (219)	5.280 (364)
500 (260)	170 (12)	605 (42)	1.205 (83)	1.810 (125)	3.015 (208)	5.025 (346)
600 (316)	140 (10)	570 (39)	1.135 (78)	1.705 (118)	2.840 (196)	4.730 (326)
650 (343)	125 (9)	550 (38)	1.100 (76)	1.650 (114)	2.745 (189)	4.575 (315)
700 (371)	110 (8)	530 (36)	1.060 (73)	1.590 (110)	2.665 (184)	4.425 (305)

Material: ASTM A 216 Gr. WCC, ASTM A 352 Gr. LCC/LC2/LC3 (Table 2-1.2)

Temperature	Working Pressures by Classes, psig (Bar)					
°F (°C)	150	300	600	900	1500	2500
-20 to 10 (-29 to 38)	290 (20)	750 (52)	1.500 (103)	2.250 (155)	3.750 (259)	6.250 (431)
200 (93)	260 (18)	750 (52)	1.500 (103)	2.250 (155)	3.750 (259)	6.250 (431)
300 (149)	230 (16)	730 (50)	1.455 (100)	2.185 (151)	3.640 (251)	6.070 (419)
400 (204)	200 (14)	705 (49)	1.405 (97)	2.110 (145)	3.520 (243)	5.865 (404)
500 (260)	170 (12)	665 (46)	1.330 (92)	1.995 (137)	3.325 (229)	5.540 (382)
600 (316)	140 (10)	605 (42)	1.210 (83)	1.815 (125)	3.025 (209)	5.040 (348)
650 (343)	125 (9)	590 (41)	1.175 (81)	1.765 (122)	2.940 (203)	4.905 (338)
700 (371)	110 (8)	555 (38)	1.110 (76)	1.665 (115)	2.775 (191)	4.630 (319)

Material: ASTM A 352 Gr. LCB (Table 2-1.3)

Temperature	Working Pressures by Classes, psig (Bar)					
°F (°C)	150	300	600	900	1500	2500
-20 to 10 (-29 to 38)	265 (18)	695 (48)	1.395 (96)	2.090 (144)	3.480 (240)	5.805 (400)
200 (93)	255 (17)	660 (45)	1.320 (91)	1.980 (136)	3.300 (227)	5.505 (379)
300 (149)	230 (16)	640 (44)	1.275 (88)	1.915 (132)	3.190 (220)	5.315 (366)
400 (204)	200 (14)	615 (42)	1.230 (85)	1.845 (127)	3.075 (212)	5.125 (353)
500 (260)	170 (12)	585 (40)	1.175 (81)	1.760 (121)	2.930 (202)	4.885 (337)
600 (316)	140 (10)	550 (38)	1.105 (76)	1.655 (114)	2.755 (190)	4.595 (317)
650 (343)	125 (9)	535 (37)	1.065 (73)	1.600 (110)	2.665 (184)	4.440 (306)
700 (371)	110 (8)	510 (35)	1.025 (71)	1.535 (106)	2.560 (176)	4.270 (294)

Material: ASTM A 182 Gr. F316/F316H, ASTM A 479 Gr. 316/316H, ASTM A 351Gr. CF3M/CF8M (Table 2-2.2)

Temperature	Working Pressures by Classes, psig (Bar)					
°F (°C)	150	300	600	900	1500	2500
-20 to 10 (-29 to 38)	275 (19)	720 (50)	1.440 (99)	2.160 (149)	3.600 (248)	6.000 (414)
200 (93)	235 (16)	620 (43)	1.240 (85)	1.860 (128)	3.095 (213)	5.160 (356)
300 (149)	215 (15)	560 (39)	1.120 (77)	1.680 (116)	2.795 (193)	4.660 (321)
400 (204)	195 (13)	515 (36)	1.025 (71)	1.540 (106)	2.570 (177)	4.280 (295)
500 (260)	170 (12)	480 (33)	955 (66)	1.435 (99)	2.390 (165)	3.980 (274)
600 (316)	140 (10)	450 (31)	900 (62)	1.355 (93)	2.255 (155)	3.760 (259)
650 (343)	125 (9)	440 (30)	885 (61)	1.325 (91)	2.210 (152)	3.680 (254)
700 (371)	110 (8)	435 (30)	870 (60)	1.305 (90)	2.170 (150)	3.620 (250)



Chemical and Mechanical Requirements - Forged / bar

Composition % (Maximum Percent Unless Range is Given)									
	ASTM Standard (UNS designation)	Nominal Composition	C	Mn	P	S	Si		
Carbon Steel	A 105 (1) (2) (3)		0,35	0,60-1,05	0,035	0,040	0,10-0,35		
	A 350 LF1 (2) (3)		0,30	0,60-1,35	0,035	0,040	0,15-0,30		
	A 350 LF2 (2) (3)		0,30	0,60-1,35	0,035	0,040	0,15-0,30		
Low Alloy	A 350 LF3 (3)		0,20	0,90	0,035	0,040	0,20-0,35		
	A 29 Gr.4140		0,38-0,43	0,75-1,00	0,035	0,040	0,15-0,35		
	A 29 Gr.4340		0,38-0,43	0,60-0,80	0,035	0,040	0,15-0,35		
	A 182 F1	(UNS K12822)	C-Mo	0,28	0,60-0,90	0,045	0,045	0,15-0,35	
	A 182 F2	(UNS K12122)	0,5Cr-0,5Mo	0,05-0,21	0,30-0,80	0,040	0,040	0,10-0,60	
	A 182 F5a	(UNS K42544)	5Cr	0,25	0,60	0,040	0,030	0,50	
	A 182 F9	(UNS K90941)	9Cr	0,15	0,30-0,60	0,030	0,030	0,50-1,00	
	A 182 F11 CL.3	(UNS K11572)	1,25Cr-0,5Mo	0,10-0,20	0,30-0,80	0,040	0,040	0,50-1,00	
	A 182 F12 CL.2	(UNS K11564)	1Cr-0,5Mo	0,10-0,20	0,30-0,80	0,040	0,040	0,10-0,60	
	A 182 F22 CL.3	(UNS K21590)	Cr-Mo	0,05-0,15	0,30-0,60	0,040	0,040	0,50	
	Martensitic	A182 F6a CL.2	(UNS S41000)	13Cr	0,15	1,00	0,040	0,030	1,00
A 182 F6NM		(UNS S41500)	13Cr-4Ni	0,05	0,5-1,0	0,030	0,030	0,60	
Austenitic Stainless Steel	A 182 F304 (4)	(UNS S30400)	18Cr-8Ni	0,08	2,00	0,045	0,030	1,00	
	A 182 F304H (4)	(UNS S30409)	18Cr-8Ni	0,04-0,10	2,00	0,045	0,030	1,00	
	A 182 F304L (4)	(UNS S30403)	18Cr-8Ni	0,035	2,00	0,045	0,030	1,00	
	A 182 F316 (4)	(UNS S31600)	18Cr-10Ni-Mo	0,08	2,00	0,045	0,030	1,00	
	A 182 F316H (4)	(UNS S31609)	18Cr-10Ni-Mo	0,04-0,10	2,00	0,045	0,030	1,00	
	A 182 F316L (4)	(UNS S31603)	18Cr-10Ni-Mo	0,030	2,00	0,045	0,030	1,00	
	A 182 F310	(UNS S31000)	25Cr-20Ni	0,25	2,00	0,045	0,030	1,00	
	A 182 F44	(UNS S31254)	20Cr-18Ni-6Mo	0,020	1,00	0,030	0,010	0,80	
	B 462- UNS N08020	(ALLOY 20)	29Ni-20Ni-3Cu-2Mo	0,07	2,00	0,045	0,035	1,00	
Austenitic Ferritic Stainless Steel	A 182 F51	(UNS S31803)	22Cr-5Ni	0,030	2,00	0,030	0,020	1,00	
	A 182 F53	(UNS S32750)	25Cr-7Ni-4Mo	0,030	1,20	0,035	0,020	0,80	
	A 182 F55	(UNS S32760) (5)	25Cr-7Ni-3,5Mo	0,030	1,00	0,030	0,010	1,00	
Age hardened SS	A 564 Gr 630 H900	(UNS S17400)	16Cr-4Ni-4Cu	0,07	1,00	0,040	0,030	1,00	
	A 564 Gr 630 H1150M	(UNS S17400)	16Cr-4Ni-4Cu	0,07	1,00	0,040	0,030	1,00	
Titanium	B 348 Gr.3	(Unalloyed Titanium)	Ti	0,08	Ti=Balance	H=0,015	Fe=0,30	O=0,35	
	B 348 Gr.5	(Titanium Alloy)	6Al-4V	0,08	Ti=Balance	H=0,015	Fe=0,40	O=0,20	
Nickel Alloy	B 564-UNS N06625	(INCONEL 625)	60Ni-22Cr-9Mo-3,5Cb	0,10	0,5	0,015	0,015	0,5	
	B 564-UNS N08825	(INCONEL 825)		0,05	1,0		0,03	0,5	

- (1) For each reduction of 0,01% below the specified maximum carbon content, an increase of 0,06% Mn above the specified maximum will be permitted up to a maximum of 1,35%.
- (2) $Cu + Ni + Cr + Mo \leq 1,00\%$



Materials for Body, Plug, Cover and Stem Components

						Mechanical Properties			
Cr	Mo	Ni	Cu	V	Others Elements	Tensile Strength min, ksi (MPa)	Yield Strength min, ksi (MPa)	Elongation min%	Reduction of area min%
0,30	0,12	0,40	0,40	0,08	Cb = 0,02	70 (485)	36 (250)	22	30
0,30	0,12	0,40	0,40	0,08	Cb=0,02	60 (415)	30 (205)	25	38
0,30	0,12	0,40	0,40	0,08	Cb=0,02	70 (485)	36 (250)	22	30
0,30	0,12	3,3-3,7	0,40	0,03	Cb=0,02	70 (485)	37,5 (260)	22	35
0,80-1,10	0,15-0,25	-	-	-	-	100 (690)	75 (520)	20	50
0,70-0,90	0,20-0,30	1,65-2,00	-	-	-	115 (790)	96 (660)	16	45
-	0,44-0,65	-	-	-	-	70 (485)	40 (275)	20	30
0,50-0,81	0,44-0,65	-	-	-	-	70 (485)	40 (275)	20	30
4,0-6,0	0,44-0,65	0,50	-	-	-	90 (620)	65 (450)	22	50
8,0-10,0	0,90-1,10	-	-	-	-	85 (585)	55 (380)	20	40
1,00-1,50	0,44-0,65	-	-	-	-	75 (515)	45 (310)	20	30
0,80-1,25	0,44-0,65	-	-	-	-	70 (485)	40 (275)	20	30
2,00-2,50	0,87-1,13	-	-	-	-	75 (515)	45 (310)	20	30
11,5-13,5	-	0,50	-	-	-	85 (585)	55 (380)	18	35
11,5-14,0	0,5-1,0	3,5-5,5	-	-	-	115 (790)	90 (620)	15	45
18,0-20,0	-	8,0-11,0	-	-	-	75 (515)	30 (205)	30	50
18,0-20,0	-	8,0-11,0	-	-	-	75 (515)	30 (205)	30	50
18,0-20,0	-	8,0-13,0	-	-	-	70 (485)	25 (170)	30	50
16,0-18,0	2,00-3,00	10,0-14,0	-	-	-	75 (515)	30 (205)	30	50
16,0-18,0	2,00-3,00	10,0-14,0	-	-	-	75 (515)	30 (205)	30	50
16,0-18,0	2,00-3,00	10,0-15,0	-	-	-	70 (485)	25 (170)	30	50
19,0-22,0	-	24,0-26,0	-	-	-	75 (515)	30 (205)	30	50
19,5-20,5	6,0-6,5	17,5-18,5	0,5-1,0	-	N=0,18-0,22	94 (650)	44 (300)	35	50
19,00-21,00	2,00-3,00	32,00-38,00	3,00-4,00	-	-	80 (551)	35 (241)	30	50
21,0-23,0	2,5-3,5	4,5-6,5	-	-	N=0,08-0,20	90 (620)	65 (450)	25	45
24,0-26,0	3,0-5,0	6,0-8,0	0,5	-	N=0,24-0,32	116 (800)	80 (550)	15	-
24,0-26,0	3,0-4,0	6,0-8,0	0,50-1,00	N=0,20-0,30	W=0,50-1,00	109 (750)	80 (550)	25	45
15,0-17,5	-	3,00-5,00	3,00-5,00	-	-	190 (1.310)	170 (1.170)	10	40
15,0-17,5	-	3,00-5,00	3,00-5,00	-	-	115 (795)	75 (515)	18	55
-	-	-	-	-	N=0,05	65 (450)	55 (380)	18	30
Al=5,5-6,75	-	-	-	3,5-4,5	N=0,05	130 (895)	120 (828)	10	25
20,0-23,0	8,0-10,0	58,0Min	Ta+Cb=3,15-4,15	Ti=0,4	Fe=5,0Al=0,4	110 (758)	50 (345)	25	-
19,5-23,5	2,5-3,5	38,0-46,0	1,5-3,0	Ti=0,6-1,2	Fe=22,0Al=0,2	85 (586)	35 (241)	30	-

(3) $Cr + Mo \leq 0,32\%$

(4) Maximum nitrogen content of 0,10%

(5) Pitting Resistance Equivalent Number (PREN) = $Cr + 3,3Mo + 16N \leq 40$.



Chemical and Mechanical Requirements - Cast Materials

Composition % (Maximum Percent Unless Range is Given)

	ASTM Standard (UNS designation)	Nominal Composition	C	Mn	P	S	Si
Carbon Steel	A 216 WCB (2)		0,30	1,00	0,035	0,035	0,60
	A 216 WCC (2)		0,25	1,20	0,035	0,035	0,60
	A 352 LCB (UNS J03003) (2)		0,30	1,00	0,040	0,045	0,60
	A 352 LCC (UNS J02505) (2)		0,25	1,20	0,040	0,045	0,60
	A 352 LC3 (UNS J31550)	3,5Ni	0,15	0,50-0,80	0,040	0,045	0,60
	A 487 Gr4Q 4-C	Ni-Cr-Mo	0,030	1,00	0,040	0,045	0,80
Low Alloy	A 217 WC1	C-Mo	0,25	0,50-0,80	0,040	0,045	0,60
	A 217 WC6	Cr-Mo	0,05-0,20	0,50-0,80	0,035	0,035	0,60
	A 217 WC9	Cr-Mo	0,05-0,18	0,40-0,70	0,035	0,035	0,60
	A 217 C5	Cr-Mo	0,20	0,40-0,70	0,040	0,045	0,75
	A 217 C12	Cr-Mo	0,20	0,35-0,65	0,035	0,035	1,00
Martensitic	A 217 CA15 (UNS J91150)	13Cr	0,15	1,00	0,040	0,025	1,50
	A 487 CA6NM (UNS J91540)	13Cr-4Ni	0,06	1,00	0,040	0,030	1,00
Austenitic Stainless Steel	A 351 CF3 (UNS J92500)	18Cr-8Ni	0,03	1,50	0,040	0,040	2,00
	A 351 CF3M (UNS J92800)	16Cr-12Ni-2Mo	0,03	1,50	0,040	0,040	1,50
	A 351 CF8 (UNS J92600)	18Cr-8Ni	0,08	1,50	0,040	0,040	2,00
	A 351 CF8C (UNS 92710) (1)	18Cr-10Ni-2Co	0,08	1,50	0,040	0,040	2,00
	A 351 CF8M (UNS J92900)	16Cr-12Ni-2Mo	0,08	1,50	0,040	0,040	1,50
	A 351 CN7M (UNS N08007)	29Ni-20Cr-3Cu-2Mo	0,07	1,50	0,040	0,040	1,50
	A 351 CK3MCuN (UNS J93254) (3)	20Cr-18Ni-6Mo-N	0,025	1,20	0,045	0,010	1,00
Cast Austenitic Ferritic (Duplex) Stainless Steel	A 890 CD3MN (UNS J92205)	22Cr-5Ni-Mo-N	0,03	1,50	0,040	0,020	1,00
	A 890 CE3MN (UNS J93404) (3)	25Cr-7Ni-Mo-N	0,03	1,50	0,040	0,040	1,00
	A 890 CD3MWCuN (UNS J93380)(3)	25Cr-7Ni-Mo-N	0,03	1,00	0,030	0,025	1,00

Chemical and Mechanical Requirements Bolting Materials

Stud	A 193 B7 and B7M (5)	Cr-Mo	0,38-0,48	0,75-1,00	0,035	0,040	0,15-0,35
	A 193 B16	Cr-Mo-V	0,36-0,47	0,45-0,70	0,035	0,040	0,15-0,35
	A 193 B8M CL.2	18Cr-10Ni-2Mo	0,08	2,00	0,045	0,030	1,00
	A 320 L43	Ni-Cr-Mo	0,38-0,43	0,60-0,85	0,035	0,040	0,15-0,35
	A 320 L7 and L7M (5)	Cr-Mo	0,38-0,48	0,75-1,00	0,035	0,040	0,15-0,35
	A 453 Gr 660A		0,08	2,00	0,040	0,030	1,00
Nut	A 194 2H/2HM	C	min 0,40	1,00	0,040	0,050	0,40
	A 194 4	C-Mo	0,40-0,50	0,70-0,90	0,035	0,040	0,15-0,35
	A 194 7/7M	Cr-Mo	0,38-0,48	0,75-1,00	0,035	0,040	0,15-0,35
	A 194 8M	18Cr-10Ni-2Mo	0,08	2,00	0,045	0,030	1,00

- (1) Grade CF8C shall have a columbium content of not less than 8 times the carbon content but not over 1,00%
 (2) For each reduction of 0,01% below the specified maximum carbon content, and increase of 0,04% Mn above the specified maximum will be permitted up to a maximum of: 1,28% for WCB and LCB; 1,40% for WCC and LCC.



for Body, Plug and Cover Components

						Mechanical Properties			
Cr	Mo	Ni	Cu	V	W	Tensile Strength min, ksi (MPa)	Yield Strength min, ksi (MPa)	Elongation min%	Reduction of area min%
0,50	0,20	0,50	0,30	0,03	-	70 (485)	36 (250)	22	35
0,50	0,20	0,50	0,30	0,03	-	70 (485)	40 (275)	22	35
0,50	0,20	0,50	0,30	0,03	-	65 (450)	35 (240)	24	35
0,50	0,20	0,50	-	0,03	-	70 (485)	40 (275)	22	35
	-	3,00-4,00	-	-	-	70 (485)	40 (275)	24	35
0,40-0,80	0,15-0,30	0,4-0,80	0,50	0,03	0,10	90 (620)	60 (415)	18	35
0,35	0,45-0,65	-	0,50	-	0,10	65 (450)	35 (240)	24	35
1,00-1,50	0,45-0,65	0,50	0,50	-	0,10	70 (485)	40 (275)	20	35
2,00-2,75	0,90-1,20	0,50	0,50	-	0,10	70 (485)	40 (275)	20	35
4,00-6,50	0,45-0,65	0,50	0,50	-	0,10	90 (620)	60 (415)	18	35
8,00-10,00	0,90-1,20	0,50	0,50	-	0,10	90 (620)	60 (415)	18	35
11,50-14,00	0,50	1,00	-	-	-	90 (620)	65 (450)	18	30
11,5-14,0	0,4-1,0	3,5-4,5	0,50	0,05	0,10	100 (690)	75 (515)	17	35
17,00-21,00	0,50	8,00-12,00	-	-	-	70 (485)	30 (206)	35	-
17,00-21,00	2,00-3,00	9,00-13,00	-	-	-	70 (485)	30 (206)	30	-
18,00-21,00	0,50	8,00-11,00	-	-	-	70 (485)	30 (206)	35	-
18,00-21,00	0,50	9,00-12,00	-	-	-	70 (485)	30 (206)	30	-
18,00-21,00	2,00-3,00	9,00-12,00	-	-	-	70 (485)	30 (206)	30	-
19,0-22,0	2,0-3,0	27,5-30,5	3,0-4,0	-	-	62 (425)	25 (170)	35	-
19,5-20,5	6,0-7,0	17,5-19,5	0,50-1,00	-	N=0,18-0,24	80 (550)	38 (260)	35	-
21,0-23,5	2,5-3,5	4,5-6,5	1,00	-	N=0,10-0,30	90 (620)	60 (415)	25	-
24,0-26,0	4,0-5,0	6,0-8,0	-	-	N=0,10-0,30	100 (690)	75 (515)	18	-
24,0-26,0	3,0-4,0	6,5-8,5	0,5-1,0	-	N=0,20-0,30	100 (690)	65 (450)	25	-

(Body / Plug)

0,75-1,20	0,15-0,25	-	-	-	-	125/100 (860/690)	105/80 (720/550)	16/18	50
0,80-1,15	0,50-0,65	-	-	0,25-0,35	Al=0,015	125 (860)	105 (725)	18	50
16,0-18,0	2,00-3,00	10,0-14,0	-	-	-	110 (760)	95 (655)	15	45
0,70-0,90	0,20-0,30	1,65-2,00	-	-	-	125 (860)	105 (725)	16	50
0,80-1,10	0,15-0,25	-	-	-	-	125/100 (860/690)	105/80 (725/550)	16/18	50
13,5-16,0	1,00-1,50	24,0-27,0	-	0,10-0,50	B=0,001-0,01 Ti=1,90-2,35	130 (895)	85 (585)	15	18
-	-	-	-	-	-	--	--	-	-
-	0,20-0,30	-	-	-	-	--	--	-	-
0,8-1,10	0,15-0,25	-	-	-	-	--	--	-	-
16,0-18,0	2,00-3,00	10,0-14,0	-	-	-	--	--	-	-

(3) Pitting Resistance Equivalent Number (PREN) = Cr + 3,3Mo + 16N ≤ 40.

(4) For 3/4" (M20) and under: 110/(760), 95/(655) 15; over 3/4" (M20) up to 1" (M24): 100/(690), 80/(550), 20 over 1" M24 up to 1.25" (M30) 95/(655), 65/(450), 25 over 1.25" (M30) up to 1.5" (M36): 90/(620), 50/(345), 30.

(5) For B7M and L7M grades, a minimum carbon content of 0,28% is permitted, provided that the required tensile properties are met in the section size involved.



Plug Valve Dimensions According to API Std. 6D/ISO14313

Face to Face (A) and End to End (B - C) dimensions in mm.

NPS (DN)	Short Welding End			Reduced (Regular) Welding End			Venturi Welding End			Round-Port, Full Bore Ring Joint		
	Raised Face	Welding End	Ring Joint	Raised Face	Welding End	Ring Joint	Raised Face	Welding End	Ring Joint	Raised Face	Welding End	Ring Joint
1 Inch/mm	2 A	3 B	4 C	5 A	6 B	7 C	8 A	9 B	10 C	11 A	12 B	13 C
CLASS 150 (PN 20)												
2 (50)	178	267	191	-	-	-	-	-	-	267	-	279
2 1/2 (65)	191	305	203	-	-	-	-	-	-	298	-	311
3 (80)	203	330	216	-	-	-	-	-	-	343	-	356
4 (100)	229	356	241	-	-	-	-	-	-	432	-	445
6 (150)	267	457	279	394	-	406	-	-	-	546	-	559
8 (200)	292	521	305	457	-	470	-	-	-	622	-	635
10 (250)	330	559	343	533	-	546	533	559	546	660	-	673
12 (300)	356	635	368	610	-	622	610	635	622	762	-	775
14 (350)	-	-	-	-	-	-	686	686	699	-	-	-
16 (400)	-	-	-	-	-	-	762	762	775	-	-	-
18 (450)	-	-	-	-	-	-	864	864	876	-	-	-
20 (500)	-	-	-	-	-	-	914	914	927	-	-	-
24 (600)	-	-	-	-	-	-	1067	1067	1080	-	-	-
CLASS 300 (PN50)												
2 (50)	216	267	232	-	-	-	-	-	-	283	283	298
2 1/2 (65)	241	305	257	-	-	-	-	-	-	330	330	346
3 (80)	283	330	298	-	-	-	-	-	-	387	387	403
4 (100)	305	356	321	-	-	-	-	-	-	457	457	473
6 (150)	403	457	419	403	-	419	403	457	419	559	559	575
8 (200)	419	521	435	502	-	518	419	521	435	686	686	702
10 (250)	457	559	473	568	-	584	457	559	473	826	826	841
12 (300)	502	635	518	-	-	-	502	635	518	965	965	981
14 (350)	-	-	-	-	-	-	762	762	778	-	-	-
16 (400)	-	-	-	-	-	-	838	838	854	-	-	-
18 (450)	-	-	-	914	-	930	914	914	930	-	-	-
20 (500)	-	-	-	991	-	1010	991	991	1010	-	-	-
22 (550)	-	-	-	1092	-	1114	1092	1092	1114	-	-	-
24 (600)	-	-	-	1143	-	1165	1143	1143	1165	-	-	-
26 (650)	-	-	-	1245	-	1270	1245	1245	1270	-	-	-
28 (700)	-	-	-	1346	-	1372	1346	1346	1372	-	-	-
30 (750)	-	-	-	1397	-	1422	1397	1397	1422	-	-	-
32 (800)	-	-	-	1524	-	1553	1524	1524	1553	-	-	-
34 (850)	-	-	-	1626	-	1654	1626	1626	1654	-	-	-
36 (900)	-	-	-	1727	-	1756	1727	1727	1756	-	-	-
CLASS 400 (PN 64)												
2 (50)	-	-	-	292	292	295	-	-	-	330	-	333
2 1/2 (65)	-	-	-	330	330	333	-	-	-	381	-	384
3 (80)	-	-	-	356	356	359	-	-	-	445	-	448
4 (100)	-	-	-	406	406	410	-	-	-	483	559	486
6 (200)	-	-	-	495	495	498	495	495	498	610	711	613
8 (200)	-	-	-	597	597	600	597	597	600	737	845	740
10 (250)	-	-	-	673	673	676	673	673	676	889	889	892
12 (300)	-	-	-	762	762	765	762	762	765	1016	1016	1019
14 (350)	-	-	-	-	-	-	826	826	829	-	-	-
16 (400)	-	-	-	-	-	-	902	902	905	-	-	-
18 (450)	-	-	-	-	-	-	978	978	981	-	-	-
20 (500)	-	-	-	-	-	-	1054	1054	1060	-	-	-
22 (550)	-	-	-	-	-	-	1143	1143	1153	-	-	-
24 (600)	-	-	-	-	-	-	1232	1232	1241	-	-	-
26 (650)	-	-	-	-	-	-	1308	1308	1321	-	-	-
28 (700)	-	-	-	-	-	-	1397	1397	1410	-	-	-
30 (750)	-	-	-	-	-	-	1524	1524	1537	-	-	-
32 (800)	-	-	-	-	-	-	1651	1651	1667	-	-	-
34 (850)	-	-	-	-	-	-	1778	1778	1794	-	-	-
36 (900)	-	-	-	-	-	-	1880	1880	1895	-	-	-

Tolerance: +/-2 mm. on sizes 10 in. (DN250) and smaller. +/-3 mm on sizes 12 in. (DN300) and larger.



Plug Valve Dimensions According to API Std. 6D/ISO14313

Face to Face (A) and End to End dimensions in mm.

NPS (DN)	Reduced (Regular)			Venturi			Round-Port , Full Bore		
	Raised Face	Welding End	Ring Joint	Raised Face	Welding End	Ring Joint	Raised Face	Welding End	Ring Joint
1 Inch/mm	2 A	3 B	4 C	5 A	6 B	7 C	8 A	9 B	10 C
CLASS 600 (PN 100)									
2 (50)	292	292	295	-	-	-	330	-	333
2 1/2 (65)	330	330	333	-	-	-	381	-	384
3 (80)	356	356	359	-	-	-	445	-	448
4 (100)	432	432	435	-	-	-	508	559	511
6 (150)	559	559	562	559	559	562	660	711	664
8 (200)	660	660	664	660	660	664	794	845	797
10 (250)	787	787	791	787	787	791	940	1016	943
12 (300)	-	-	-	838	838	841	1067	1067	1070
14 (350)	-	-	-	889	889	892	-	-	-
16 (400)	-	-	-	991	991	994	-	-	-
18 (450)	-	-	-	1092	1092	1095	-	-	-
20 (500)	-	-	-	1194	1194	1200	-	-	-
22 (550)	-	-	-	1295	1295	1305	-	-	-
24 (600)	-	-	-	1397	1397	1407	-	-	-
26 (650)	-	-	-	1448	1448	1461	-	-	-
30 (750)	-	-	-	1651	1651	1664	-	-	-
32 (800)	-	-	-	1778	1778	1794	-	-	-
34 (850)	-	-	-	1930	1930	1946	-	-	-
36 (900)	-	-	-	2083	2083	2099	-	-	-
CLASS 900 (PN 150)									
2 (50)	368	-	371	-	-	-	381	-	384
2 1/2 (65)	419	-	422	-	-	-	432	-	435
3 (80)	381	381	384	-	-	-	470	-	473
4 (100)	457	457	460	-	-	-	559	-	562
6 (150)	610	610	613	610	610	613	737	-	740
8 (200)	737	737	740	737	737	740	813	-	816
10 (250)	838	838	841	838	838	841	965	-	968
12 (300)	-	-	-	965	965	968	1118	-	1121
16 (400)	-	-	-	1130	1130	1140	-	-	-
CLASS 1500 (PN 250)									
2 (50)	368	-	371	-	-	-	391	-	394
2 1/2 (65)	419	-	422	-	-	-	454	-	457
3 (80)	470	470	473	-	-	-	524	-	527
4 (100)	546	546	549	-	-	-	625	-	629
6 (150)	705	705	711	705	705	711	787	-	794
8 (200)	832	832	841	832	832	841	889	-	899
10 (250)	991	991	1000	991	991	1000	1067	-	1076
12 (300)	1130	1130	1146	1130	1130	1146	1219	-	1235
CLASS 2500 (PN 420)									
2 (50)	451	-	454	-	-	-	-	-	-
2 1/2 (65)	508	-	514	-	-	-	-	-	-
3 (80)	578	-	584	-	-	-	-	-	-
4 (100)	673	-	683	-	-	-	-	-	-
6 (150)	914	-	927	-	-	-	-	-	-
8 (200)	1022	-	1038	-	-	-	-	-	-
10 (250)	1270	-	1292	-	-	-	-	-	-
12 (300)	1422	-	1445	-	-	-	-	-	-



Application

Pipeline Isolation

Line Isolation is the most important point when the valve must shut-off the line, in process where sensitive fluid is critical for environmental and process safety. Dual seal plug valve is suitable to guarantee «0» leakage in both ends, (inlet/outlet), therefore it is the ideal solution as an isolation valve.

Flow Meter Calibration

One of the main applications of DBB expanding plug valve is for calibration of flow meter instrument on line, where «0» leakage allows the operator to set-up the instrument (flow-meter) without any risk of error in the measurement system of flow rate from wellheads through flow lines, gathering lines and high pressure transmission system in gas pipeline or in petrochemical plants or other processing.

Manifolds

Another application of DBB expanding plug valve is in Refineries at the manifolds loop, where there are different products (e.g. gasoline-diesel-jet fuel) without any contamination or risk to mix them up. Two, three or four way valves can be supplied.

Terminals-Oil Depots

The application of DBB expanding plug valves for loading and unloading tankers, requires the guarantee of a positive shut-off of the valves in order to avoid any environmental damage due to spillage.

Aviation Fuel Operation

Aviation fuel operation is commonly used in Airports. The DBB valves must guarantee a quickly close and reliable seal integrity. In case of emergency, the DBB valve can be dismantled very quickly and repaired by the replacement of the slips without any other adjustment, and put in operation very fast.

Actuators



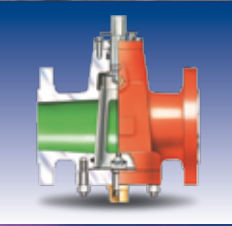
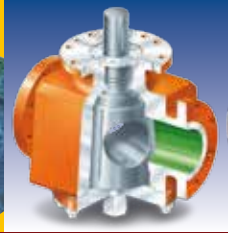
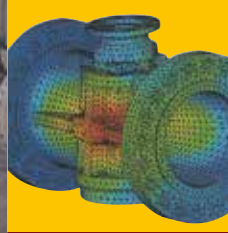

AdverTime-MI

G&C B05-2015

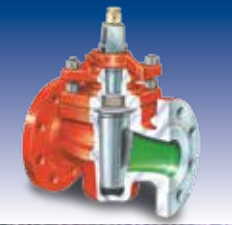

Алматы (7273)495-231
Ангарск (3955)60-70-56
Архангельск (8182)63-90-72
Астрахань (8512)99-46-04
Барнаул (3852)73-04-60
Белгород (4722)40-23-64
Благовещенск (4162)22-76-07
Брянск (4832)59-03-52
Владивосток (423)249-28-31
Владикавказ (8672)28-90-48
Владимир (4922) 49-43-18
Волгоград (844)278-03-48
Вологда (8172)26-41-59
Воронеж (473)204-51-73
Екатеринбург (343)384-55-89

Ижевск (3412)26-03-58
Иваново (4932)77-34-06
Иркутск (395)279-98-46
Казань (843)206-01-48
Калининград (4012)72-03-81
Калуга (4842)92-23-67
Кемерово (3842)65-04-62
Киров (8332)68-02-04
Коломна (4966)23-41-49
Кострома (4942)77-07-48
Краснодар (861)203-40-90
Красноярск (391)204-63-61
Курск (4712)77-13-04
Курган (3522)50-90-47
Липецк (4742)52-20-81

Киргизия (996)312-96-26-47

Магнитогорск (3519)55-03-13
Москва (495)268-04-70
Мурманск (8152)59-64-93
Набережные Челны (8552)20-53-41
Нижний Новгород (831)429-08-12
Новокузнецк (3843)20-46-81
Новосибирск (383)227-86-73
Ноябрьск (3496)41-32-12
Омск (3812)21-46-40
Орел (4862)44-53-42
Оренбург (3532)37-68-04
Пенза (8412)22-31-16
Петрозаводск (8142)55-98-37
Псков (8112)59-10-37

Россия (495)268-04-70

Пермь (342)205-81-47
Ростов-на-Дону (863)308-18-15
Рязань (4912)46-61-64
Самара (846)206-03-16
Саранск (8342)22-96-24
Санкт-Петербург (812)309-46-40
Саратов (845)249-38-78
Севастополь (8692)22-31-93
Симферополь (3652)67-13-56
Смоленск (4812)29-41-54
Сочи (862)225-72-31
Ставрополь (8652)20-65-13
Сыктывкар (8212)25-95-17
Сургут (3462)77-98-35
Тамбов (4752)50-40-97

Казахстан (772)734-952-31

Тверь (4822)63-31-35
Тольяти (8482)63-91-07
Томск (3822)98-41-53
Тула (4872)33-79-87
Тюмень (3452)66-21-18
Улан-Удэ (3012)59-97-51
Ульяновск (8422)24-23-59
Уфа (347)229-48-12
Хабаровск (4212)92-98-04
Чебоксары (8352)28-53-07
Челябинск (351)202-03-61
Череповец (8202)49-02-64
Чита (3022)38-34-83
Якутск (4112)23-90-97
Ярославль (4852)69-52-93

<https://gallicassina.nt-rt.ru> || gnj@nt-rt.ru