

Алматы (7273)495-231
Ангарск (3955)60-70-56
Архангельск (8182)63-90-72
Астрахань (8512)99-46-04
Барнаул (3852)73-04-60
Белгород (4722)40-23-64
Благовещенск (4162)22-76-07
Брянск (4832)59-03-52
Владивосток (423)249-28-31
Владикавказ (8672)28-90-48
Владимир (4922) 49-43-18
Волгоград (844)278-03-48
Вологда (8172)26-41-59
Воронеж (473)204-51-73
Екатеринбург (343)384-55-89

Ижевск (3412)26-03-58
Иваново (4932)77-34-06
Иркутск (395)279-98-46
Казань (843)206-01-48
Калининград (4012)72-03-81
Калуга (4842)92-23-67
Кемерово (3842)65-04-62
Киров (8332)68-02-04
Коломна (4966)23-41-49
Кострома (4942)77-07-48
Краснодар (861)203-40-90
Красноярск (391)204-63-61
Курск (4712)77-13-04
Курган (3522)50-90-47
Липецк (4742)52-20-81

Магнитогорск (3519)55-03-13
Москва (495)268-04-70
Мурманск (8152)59-64-93
Набережные Челны (8552)20-53-41
Нижний Новгород (831)429-08-12
Новокузнецк (3843)20-46-81
Ноябрьск (3496)41-32-12
Новосибирск (383)227-86-73
Ноябрьск (3496)41-32-12
Омск (3812)21-46-40
Орел (4862)44-53-42
Оренбург (3532)37-68-04
Пенза (8412)22-31-16
Петрозаводск (8142)55-98-37
Псков (8112)59-10-37

Пермь (342)205-81-47
Ростов-на-Дону (863)308-18-15
Рязань (4912)46-61-64
Самара (846)206-03-16
Саранск (8342)22-96-24
Санкт-Петербург (812)309-46-40
Саратов (845)249-38-78
Севастополь (8692)22-31-93
Симферополь (3652)67-13-56
Смоленск (4812)29-41-54
Сочи (862)225-72-31
Ставрополь (8652)20-65-13
Сыктывкар (8212)25-95-17
Сургут (3462)77-98-35
Тамбов (4752)50-40-97

Тверь (4822)63-31-35
Тольяти (8482)63-91-07
Томск (3822)98-41-53
Тула (4872)33-79-87
Тюмень (3452)66-21-18
Улан-Удэ (3012)59-97-51
Ульяновск (8422)24-23-59
Уфа (347)229-48-12
Хабаровск (4212)92-98-04
Чебоксары (8352)28-53-07
Челябинск (351)202-03-61
Череповец (8202)49-02-64
Чита (3022)38-34-83
Якутск (4112)23-90-97
Ярославль (4852)69-52-93

Киргизия (996)312-96-26-47

Россия (495)268-04-70

Казахстан (772)734-952-31

<https://gallicassina.nt-rt.ru> || gnj@nt-rt.ru

КАТАЛОГ

на

полнопроходные плунжерные клапаны

сбалансированные со смазкой давлением API6D и

API6A

“FULL BORE”



PRESSURE BALANCED

TYPE WITH LGC*

LUBRICATION SYSTEM





GALLI&CASSINA Profile

Galli&Cassina is a prominent Italian Company mainly involved in the manufacture of a complete range of lubricated and non lubricated Plug Valves. It is located in Solaro near to Milano, with extensive offices and workshop covering 12000 sq. mt. area including 4500 sq. mt. of covered space. Since its foundation in 1919, Galli&Cassina has been taking part to the safety increase in refineries, chemical plants and gas pipelines all over the world, building its reputation on high quality workmanship as well on the reliability of its products.

Quality Assurance System.

After 80 years of manufacturing experience and latest technology machinery, the Galli&Cassina's Quality Assurance System has been assessed, approved and certified against the following quality assurance standards: ISO 9001 and API-Q1. Rigorous procedures and internal audits guarantee that the quality system is implemented at all stages, starting from incoming raw materials, production, final tests and up to the final delivery.

Standard Inspection and Test.

All components are subjected to a strict control, chemical analysis, mechanical properties, hardness test, heat treatment and special antifriction treatment or Electroless Nickel Plating (only for plug and stem). All NDT tests (RT, MT, PT, UT) can be carried out by internal and/or external laboratory. Each valve is hydraulically and pneumatically tested and completed with a final test book (material and test certificates). Standard or special tests witnessed by third party or qualified inspection agency can be carried out according to customer's requirements.

Customer Service.

Galli&Cassina's customer Service is always willing to assist the customer with a prompt response to "service" requests. Full after sales services assistance can be offered either at our workshop or by supplying parts in a timely and efficient manner.





Standard Features

Carbon Steel plugs are subjected to the following treatments:

A Case hardening.

B Antifriction treatment.

A) The case hardening has the purpose to increase only the hardness of the plug

surface which is subjected to wearing, keeping at the same time the mechanical properties of the base material unchanged. Consequently the base material has more toughness and resistance

against impacts.

B) The Antifriction treatment is basically carried out on the plug to obtain the following advantages:

- Low friction between plug and body.

- Low torque.

- Wear resistance.

- Resistance to seizure.



▲ Regular Pattern Plug

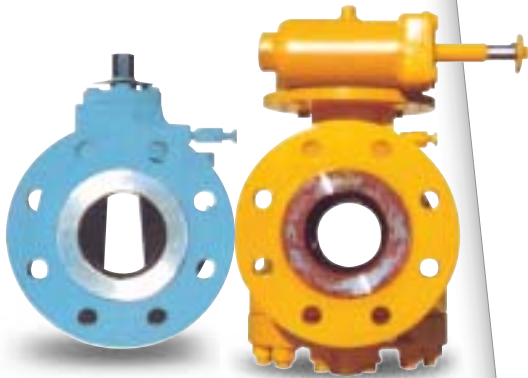

▲ Full Bore Pattern Plug

▲ The purpose of the above test is to prove that Galli&Cassina antifriction treatment made on plug surface, is guaranteed even after 30,000 cycles (open/closed position).



Pattern

Full Bore Plug Valves have API-6D face to face dimensions and a round port that is not smaller than the

minimum diameter specified in Annex A of ASME B16.34 or/and API 6D. This configuration

provides unrestricted flow and allows the passage of pigs through the valve. It is recommended

for highly abrasive services and low pressure drop as well.

Applicable Standard-Specification

Lubricated Plug Valves are designed to use with most refining and gas pipelines services according to API 599 or BS 5353 norms whichever applicable. API 6D norm aims to standardize the materials as well as instructions to manufacture valves suitable for energy transportation in the pipelines.

API 6A	Specification for wellhead and christmas tree equipment.	BS 1504	Specification for Steel Casting for Pressure Purposes.
API 6D	Specification for Pipeline Valves.	BS 2080	Face to Face - Centre to Face - End to End - Steel Valves.
API 6FA	Specification for Fire Test for Valves.	BS 5353	Specification for Steel Plug Valves.
API RP6F	Recommended - Practice for Fire Test for Valves.	BS 6755 part 1	Testing of Valves (Spec. for Production Pressure Testing Requirements).
API 598	Valve Inspection and Testing.	BS 6755 part 2	Testing of valves (Spec. for Fire Safe Testing Requirements).
API 599	Steel Plug Valves Flanged or Butt Welding Ends.		
ASME/ANSI B 16.5	Pipe Flanges and Flanged Fittings.	CSA Z 245. 15	Canadian Standard Association.
ASME/ANSI B 16.10	Face-to-Face and End-to-End Dimensions of Valves.	MSS-SP6	Standard Finish for contact Face of Pipe Flanges.
ASME/ANSI B 16.25	Buttwelding Ends.	MSS-SP25	Standard Marking System for Valves.
ASME/ANSI B 16.34	Valves-Flanged, threaded and Welding Ends.	MSS-SP44	Steel Pipe Line Flanges.
ASME/ANSI B 31.3	Chemical Plant and Petroleum Refinery Piping.	MSS-SP53	Quality Standard for Steel Casting-Magnetic Particle Examination Method.
ASME/ANSI B 31.4	Liquid Transportation System for Liquid Petroleum Gas.	MSS-SP54	Quality Standard for Steel Casting-Radiographic Examination Method.
ASME/ANSI B 31.8	Gas Transmission and Distribution Piping System.	MSS-SP55	Quality Standard for Steel Casting Visual Method.
ASME Section VIII	Rules for Construction of Pressure Vessels.	MSS-SP61	Pressure Testing of Steel Valves.
ASME Section V	Nondestructive Examination.	94/9/EC	European directive for equipment for the intended use in potentially explosive atmospheres (ATEX).
ASME Section II	Materials.	97/23/EC	Pressure equipment directive of European Community (PED).
ASNT-TC-1A	Recommended Practice for Personnel Qualification and Certification in Non destructive Testing.	ASTM	American Society for Testing and Materials.
NACE Std. MR 01.75 Latest Edition	National Association of Corrosion Engineers.		

NEW GENERATION!

*Tridimensional
CAD system and
the Finite Element
Modeling allow the
optimization of every
step of valve's design:*

- Raw Casting design (A)
- FEM stress calculation of the pressure containing parts (B)
- Final Assembly Design Check (C)

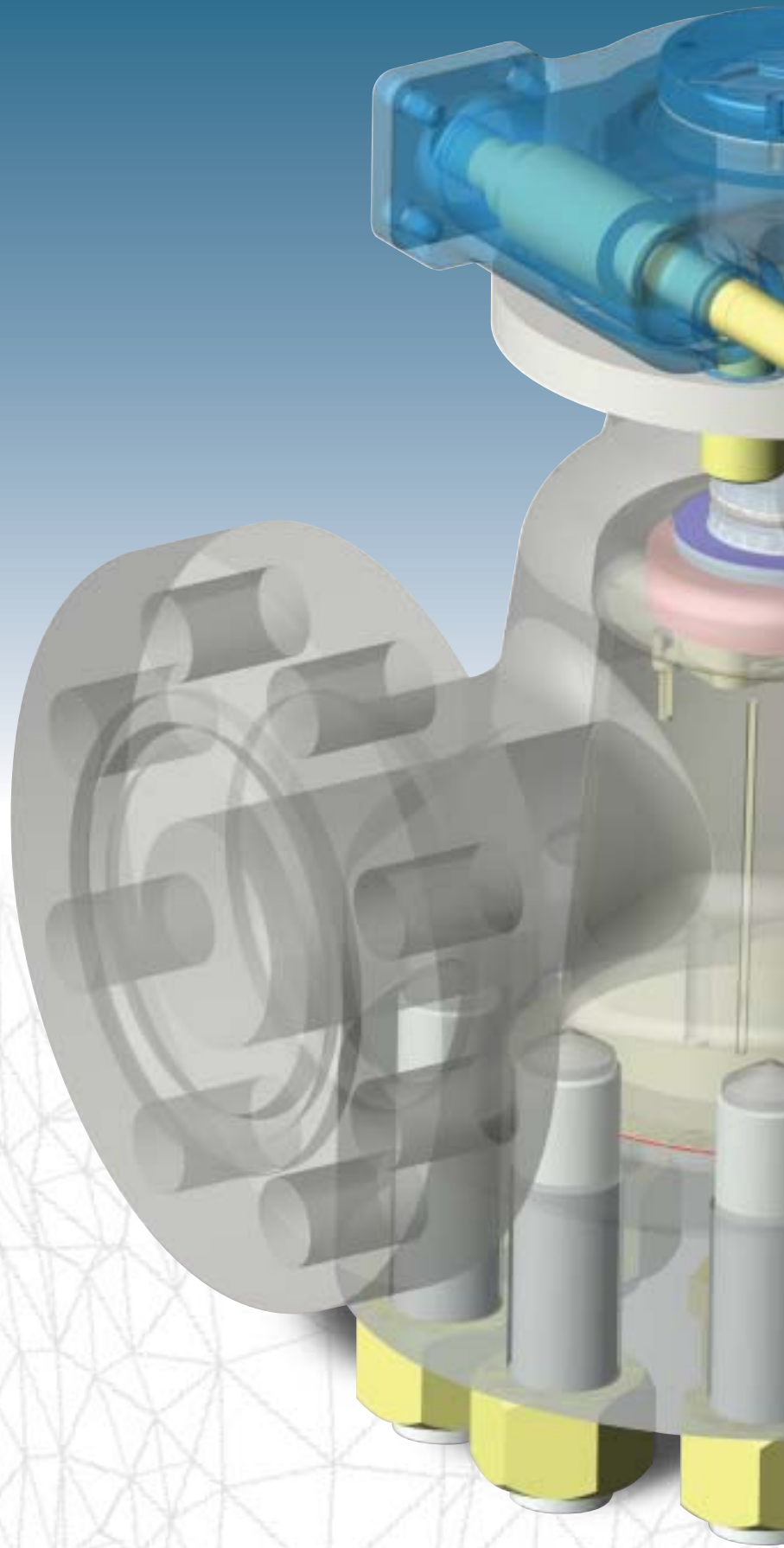
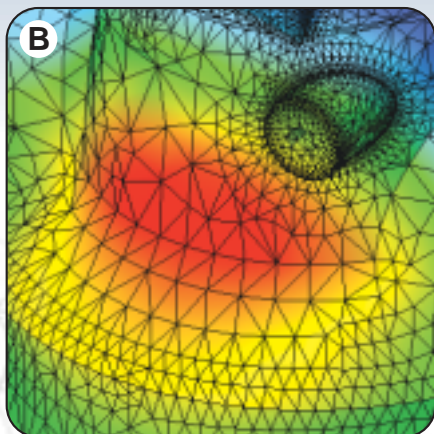



Advanced Design

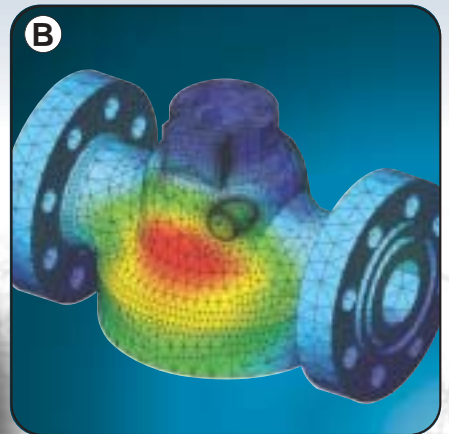
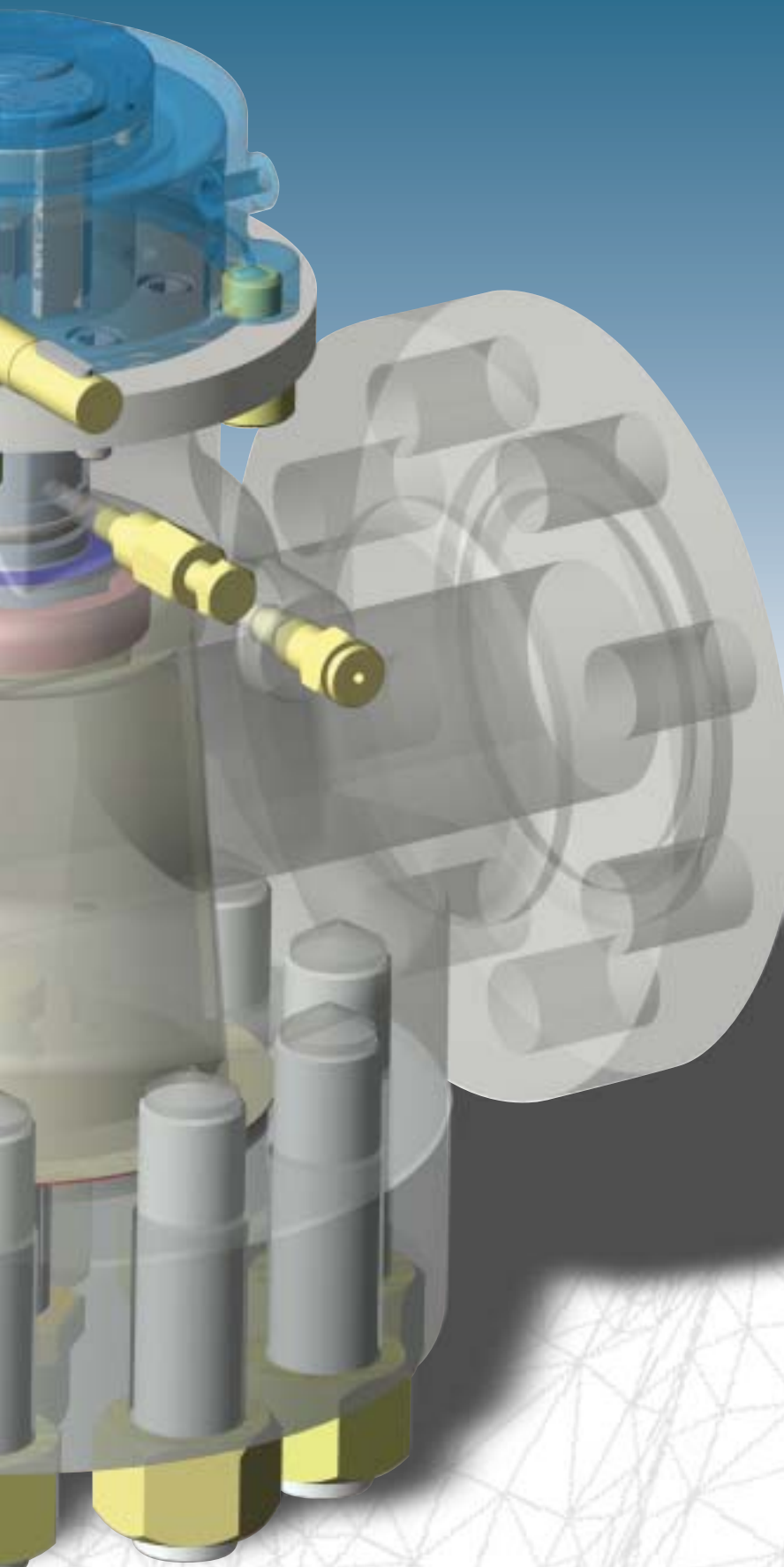



Full Bore LGC Plug Valves

Galli&Cassina is proud to introduce a new line of "Full Bore, Pressure Balanced" plug valves with **LGC*** (Low Grease Contamination) lubrication system.

Galli&Cassina has designed this new "Full Bore" plug valve in response to customer requests to provide a plug valve with the distinctive features of a ball valve for Energy applications, but with less lubrication requirements than a traditional plug valve. Thus, the LGC lubrication system of the "Full Bore" plug valve has been improved to minimize the area of contact between the fluid and the lubrication system when the valve is in the open or closed position.

Historically the regular pattern lubricated plug valve (60% -70% port area) has been used in abrasive services such as mining, slurry and blow down where the high velocity of the fluid through the port opening can erode or otherwise damage the plug seat after a short installation period-even with a hard overlay on the plug surface.

The "Full Bore" of this new valve-equal the adjacent pipe area preserves the fluid

velocity of the pipeline and minimizes the abrasive effects of the fluid on the plug port area.

guaranteed by the special design of the LGC lubricant

seat pocket or the complete body and plug seats including the internal flow passage of the valve up to the rim of the body flanges.

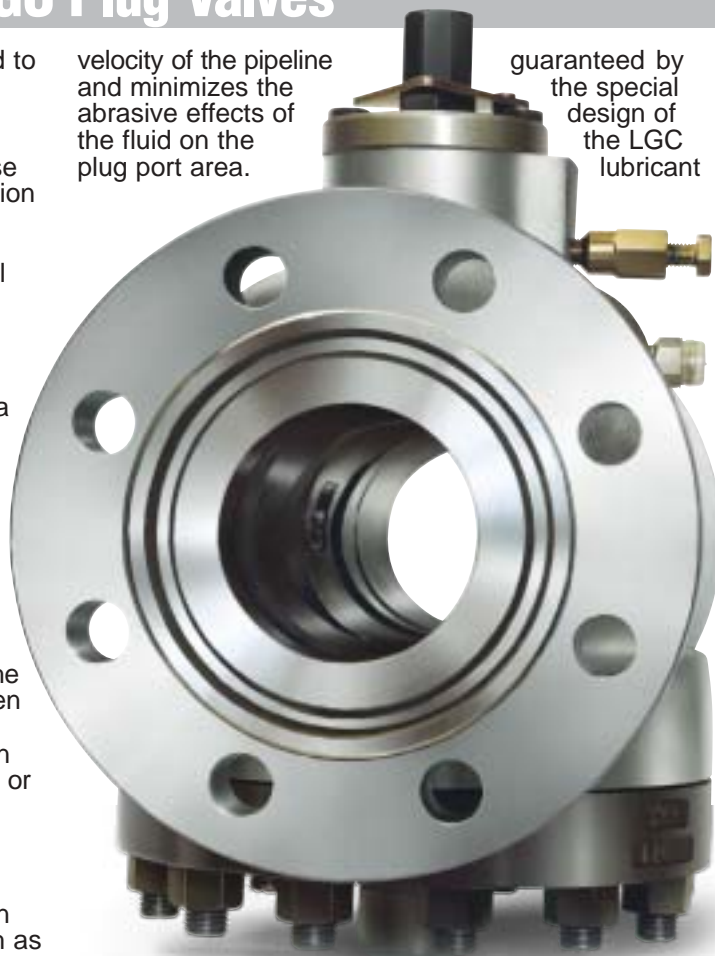

Features:

- Bubble tight in critical service.
- Less lubrication maintenance is required compared to regular pattern plug valve.
- Available in many different body and trim materials.
- Hard surface overlay is available for abrasive service: Stellite 6, 12, 21; Inconel 625, and Tungsten Carbide.
- Spare parts are not required unless requested by customer.

Applications:

- High temperature service.
 - Heavy duty services.
 - Refinery such as catalytic fluids.
 - Off-shore for dirty fluids.
 - Pig launcher drain or vent valve.
 - Blow down.
 - Drilling and wellhead.
- Galli&Cassina staff is always available at the customer's request to study any problem or application for all types of service.

After lengthy periods of operation in abrasive fluid application the result is that the metal-to-metal seat "Full Bore" plug valve is more reliable when compared to other types of metal-to-metal seated valves.

Plus, the sealing capability of this new "Full Bore" plug valve is

grease system. For high pressure and critical service a Stellite 6, 12 or 21; Inconel 625 or Tungsten Carbide hard surface overlay can be applied to the taper plug surface; the "Full Bore" plug port surface; the body

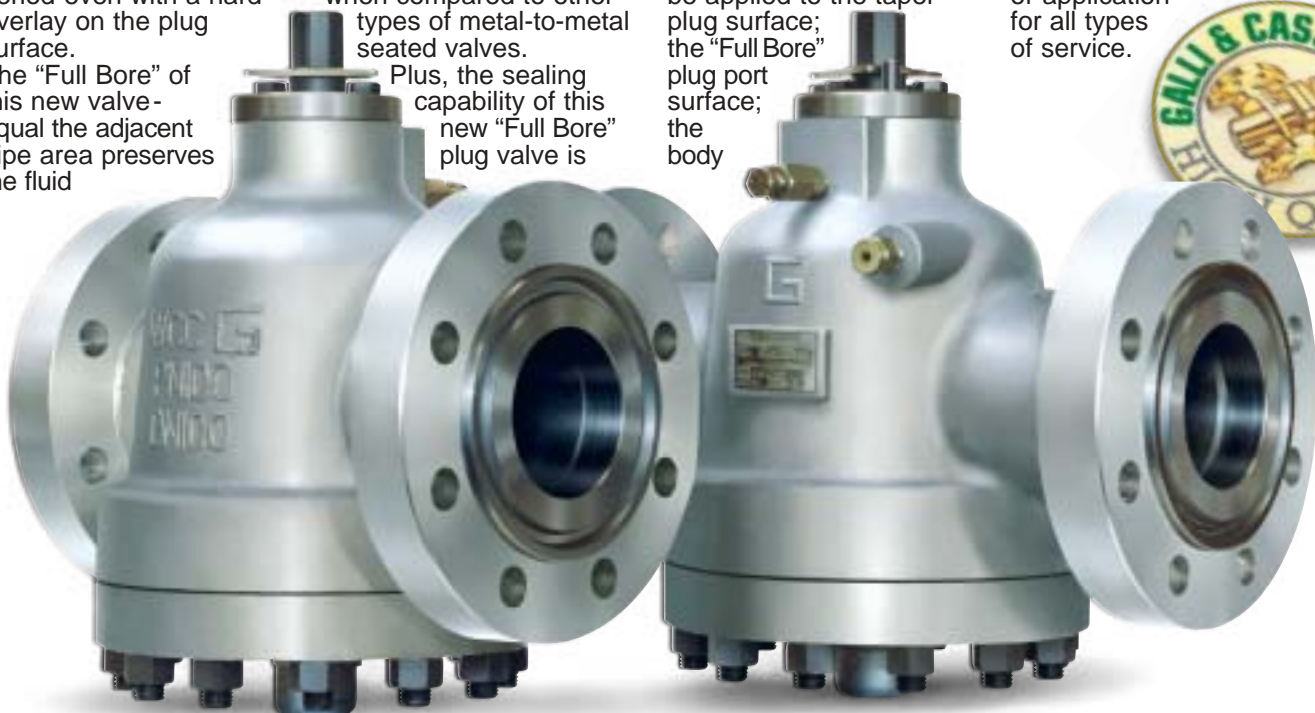

* "Italian Trademark application filed"



Cross Section Valve

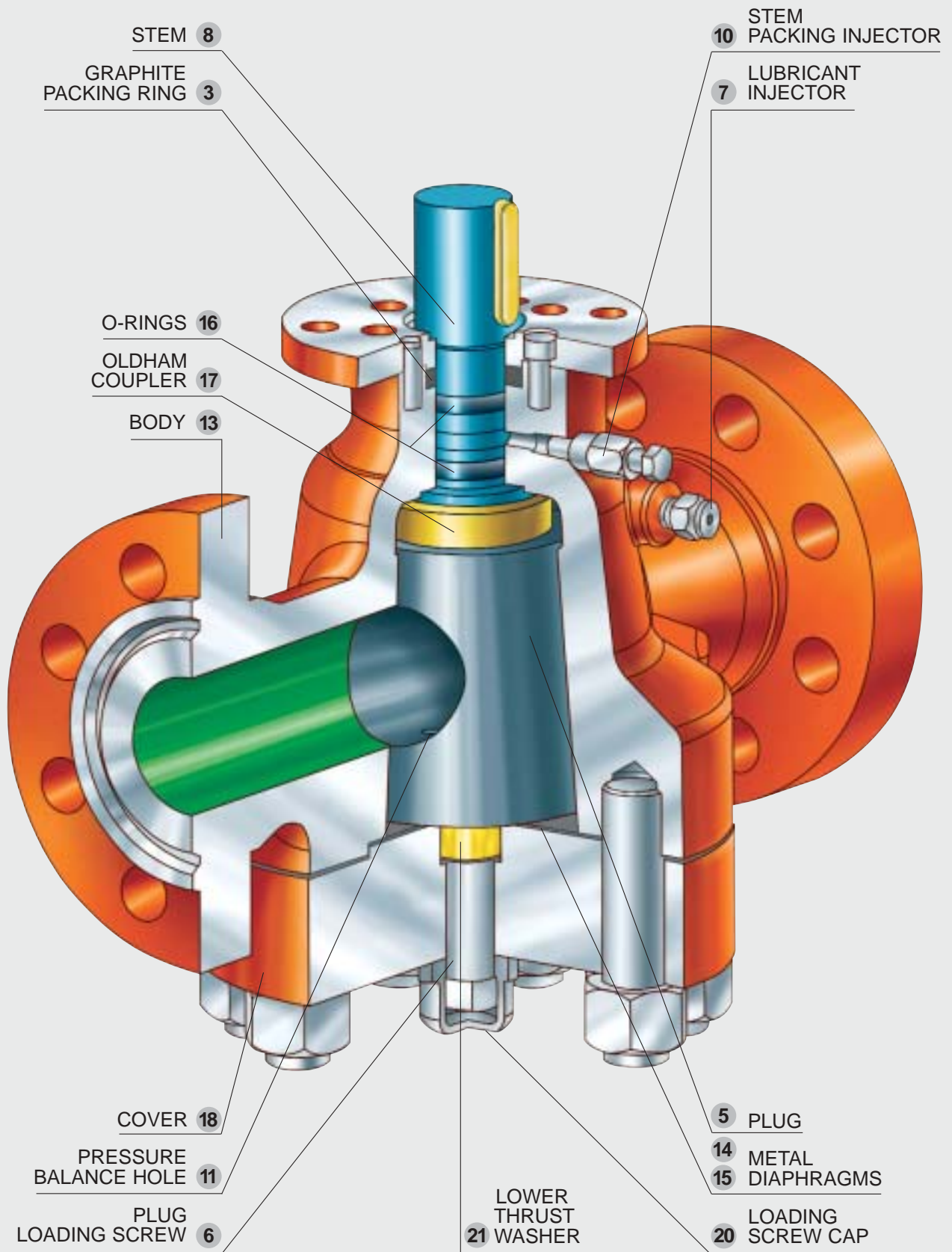



Face to Face Dimension Tables

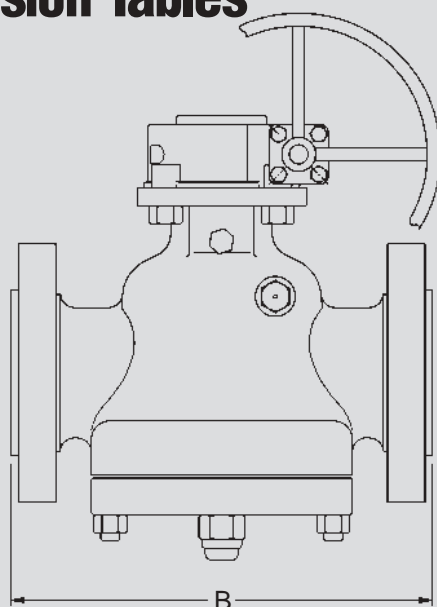

API 6D Plug Valves

	B ANSI 600/PN100 RF & BW/RTJ	B ANSI 900/PN150 RF & BW/RTJ	B ANSI 1500/PN250 RF & BW/RTJ	B ANSI 2500/PN420 RF/BW/RTJ
1"/DN25	216/216 (a)	254/254 (a)	254/254 (a)	308/308/308 (a)
1 1/2"/DN40	241/241 (a)	305/305 (a)	305/305 (a)	384/384/387 (a)
2"/DN50	292/295	368/371	368/371	451/ * /454
2 1/2"/DN65	330/333	419/422	419/422	508/ * /514
3"/DN80	356/356	381/384	470/473	578/ * /584
4"/DN100	432/435	457/460	546/549	673/ * /683
6"/DN150	559/562	610/613	705/711	914/ * /927
8"/DN200	660/663	737/740	832/841	1022/ * /1038
10"/DN250	787/790	838/841	991/1000	1270/ * /1232
12"/DN300	838/841	965/968	1130/1146	1422/ * /1445
14"/DN350	889/892	1029/1038 (a)	1257/1276 (a)	* / * / *
16"/DN400	991/994	1130/1140	1384/1406 (a)	* / * / *
18"/DN450	1092/1095	1219/1232 (a)	1537/1559 (a)	
20"/DN500	1194/1200	1321/1334 (a)	1664/1686 (a)	
22"/DN550	1295/1305	* / *	* / *	
24"/DN600	1397/1407	1549/1568 (a)	1943/1962 (a)	

(*) To be agreed with the end user - (a) Face to face dimension extrapolated from ASME B16.10

API 6A Plug Valves

	B API 2000/PN138 RF & BW/RTJ	B API 3000/PN207 RF & BW/RTJ	B API 5000/PN345 RF & BW/RTJ	B API 10000/PN690 RTJ & BW
1 13/16"	----	----	----	464
2 1/16"	292/295	368/371	368/371	521
2 9/16"	330/333	419/422	419/422	565
3 1/16"	----	----	----	619
3 1/8"	356/356	381/384	470/473	----
4 1/16"	432/435	457/460	546/549	670
5 1/8"	----	----	----	737
7 1/16" x 6"	559/562	610/613	705/711	----
7 1/16" x 6 3/8"	----	----	----	889
7 1/16"	----	----	----	889



Pressure Test Tables in accordance with API 598 & API 6D

ASME B16.34 Group Material 1.1

(A 105; A 216 WCB; A 350 LF2)

	Working Pressures by Classes, psig (Bar)					
	150 PN20	300 PN50	600 PN100	900 PN150	1500 PN250	2500 PN420
Working pressure rating	285 (20)	740 (51)	1480 (102)	2220 (153)	3705 (255)	6170 (425)
Hydraulic body test	450 (31)	1125 (78)	2225 (153)	3350 (231)	5575 (384)	9275 (640)
Hydraulic seat test	314 (22)	814 (56)	1628 (112)	2442 (168)	4076 (281)	6787 (468)

ASME B16.34 Group Material 1.2 and 2.8

(A 350 LF6; A 216 WCC; A 352 LCC; A 182 F44/ F51; UNS S31803/S31254/S32750; A 351 Gr. CK3MCuN / CE8MN / CD4MCu / CD3MWCuN)

	Working Pressures by Classes, psig (Bar)					
	150 PN20	300 PN50	600 PN100	900 PN150	1500 PN250	2500 PN420
Working pressure rating	290 (20)	750 (52)	1500 (103)	2250 (155)	3750 (259)	6250 (431)
Hydraulic body test	450 (31)	1125 (78)	2250 (155)	3375 (233)	5625 (388)	9375 (646)
Hydraulic seat test	319(22)	825(57)	1650(114)	2475(171)	4125(284)	6875(474)

ASME B16.34 Group Material 1.3

(A 352 LCB)

	Working Pressures by Classes, psig (Bar)					
	150 PN20	300 PN50	600 PN100	900 PN150	1500 PN250	2500 PN420
Working pressure rating	265 (18)	695 (48)	1390 (96)	2085 (144)	3470 (239)	5785 (399)
Hydraulic body test	400 (28)	1050 (72)	2100 (145)	3150 (217)	5225 (360)	8700 (600)
Hydraulic seat test	292 (20)	765 (53)	1529 (105)	2294 (158)	3817 (263)	6364 (439)

ASME B16.34 Group Material 2.1 and 2.2

(A 182 F304; A 479 Gr.304; A 351 CF3; A 351 CF8; A 182 F316; A 479 Gr.316; A 351 CF3M)

	Working Pressures by Classes, psig (Bar)					
	150 PN20	300 PN50	600 PN100	900 PN150	1500 PN250	2500 PN420
Working pressure rating	275 (19)	720 (50)	1440 (99)	2160 (149)	3600 (248)	6000 (414)
Hydraulic body test	425 (29)	1100 (76)	2175 (150)	3250 (224)	5400 (372)	9000 (621)
Hydraulic seat test	303 (21)	792 (55)	1584 (109)	2376 (164)	3960 (273)	6600 (455)

ASME B16.34 Group Material 2.3

(A 182 F304/F316L; A 479 Gr.304/316L)

	Working Pressures by Classes, psig (Bar)					
	150 PN20	300 PN50	600 PN100	900 PN150	1500 PN250	2500 PN420
Working pressure rating	230 (16)	600 (41)	1200 (83)	1800 (124)	3000 (207)	5000 (345)
Hydraulic body test	350 (24)	900 (62)	1800 (124)	2700 (186)	4500 (310)	7500 (517)
Hydraulic seat test	253 (17)	660 (46)	1320 (91)	1980 (137)	3300 (228)	5500 (379)

Pressure Test Tables in accordance with API 6A

Working Pressure Rating	Hydraulic Pressure Test						High Pressure Gas Test Body & Seat
	Up to 13 5/8"		From 16 3/4"		Seat		
Bar psi	Bar psi	Bar psi	Bar psi	Bar psi	Bar psi	Bar psi	
138 2000	276 4000	207 3000	310 4500	138 2000	138 2000	138 2000	
207 3000	415 6000	310 4500	310 4500	207 3000	207 3000	207 3000	
345 5000	517 7500	517 7500	517 7500	345 5000	345 5000	345 5000	
690 10000	1035 15000	1035 15000	1035 15000	690 10000	690 10000	690 10000	
1.035 15000	1550 22500	1550 22500	1550 22500	1035 15000	1035 15000	1035 15000	
1.380 20000	2070 30000			1380 20000	1380 20000	1380 20000	



Material Selection Guide for GALLI&CASSINA Valves

Trim materials are designed according to the service conditions.

- 1 Standard Carbon Steel Body and Plug. (ASTM-A 216 WCB/WCC material) suitable for general services.
- 2 Carbon Steel Body and Plug (A352 LCB/LCC material) suitable for low temperature services.
- 3 Carbon Steel Body and Plug (ASTM A216WCB/WCC material) suitable for "SOUR SERVICE"(H₂S and CO₂) according to NACE-MR.01.75/Latest Edition.
- 4 Special Austenitic (6MO) and Ferritic-Austenitic Stainless Steel (Duplex and Superduplex) suitable for sea water and corrosive services.
- 5 Nickel-Chromium-Iron alloy (i.e. Alloy 20), Titanium & Titanium alloy, carbon steel with Inconel 625 cladding and stellite or Tungsten carbide hardfacing for abrasive/corrosive service.
- 6 Other materials upon request.

Standard Design Categories (Typical Construction Materials)

Trim Service	Class	Body/Cover	Plug	Stem and Oldham Coupler	Bolting
1 Standard service Natural gas Hydrocarbons	150 to 2500	ASTM A105 ASTM A216 WCB/WCC Max C 0.25%	ASTM A105 ASTM A216 WCB/WCC	ASTM A29 Gr. 4140	ASTM A193-B7M ASTM A194-2HM
2 Low temperature Natural gas Hydrocarbons	150 to 2500	ASTM A350-LF2 ASTM A352 LCB/LCC Max C 0.23%	ASTM A350-LF2 ASTM A352- LCB/LCC	ASTM A29 Gr. 4140	ASTM A320-L7 ASTM A194 Gr.7
3 Sour Service (H ₂ S and CO ₂) Hydrocarbons	150 to 2500	ASTM A105 ASTM A216 WCB/WCC Max C.0.23% Max HRC22	ASTM A105 ASTM A216 WCB/WCC Max C.0.23% Max HRC22	ASTM A29 Gr. 4140 Max HRC22	ASTM A193-B7M ASTM A194-2HM MAX HRC22
4 Sea Water	150 to 2500	UNS S31254 ASTM A 351 CK3MCuN (6MO)	UNS S31254	UNS S31254	ASTM A453 Gr.660A
		UNS S31803 ASTM A 890 J92205 (Duplex 22% Cr)	UNS S31803	UNS S31803	ASTM A453 Gr.660A UNS S32760
		UNS S32750 ASTM A 890 J93404 (Super duplex 25% Cr)	UNS S32750	UNS S32750	UNS S32760
		UNS S32760 ASTM A 890 J93380 (Super duplex 25% Cr)	UNS S32760	UNS S32760	UNS S32760
5 Abrasive/Corrosive Slurry service	150 to 2500	ASTM B348 Gr 3 or 5 (Titanium)	ASTM B348 GR 3 or 5	UNS S31254 UNS S32760	ASTM A453 Gr.660A
		UNS N08020 ASTM A351 CN7M (Alloy 20)	UNS N08020 ASTMA351CN7M	UNS S32750 UNS S32760	ASTM A453 Gr.660A UNS S32760
		ASTM A 105 ASTM A 216 WCB/WCC Hardfacing (Stellite/WC) and Cladding (Inconel 625)		ASTM A 29 Gr 4140	ASTM A193 B7M ASTM A194 2HM



Special Features

Hardfacing

The most common damages of valves are either due to abrasion by solids in the flow lines, or the exposure

of main components to corrosion attack. Galli&Cassina's researching and development in cooperation with specialized companies

and laboratories, have been the development of special hardfacing and corrosion resistant materials, which have achieved excellent results in Off-Shore

application. Most of the main materials used are as follows: Stellite-Duplex-6MO Inconel 625-Nickel Alloy 686 Ultimet-Alloy (UNS R31233) Tungsten Carbide.

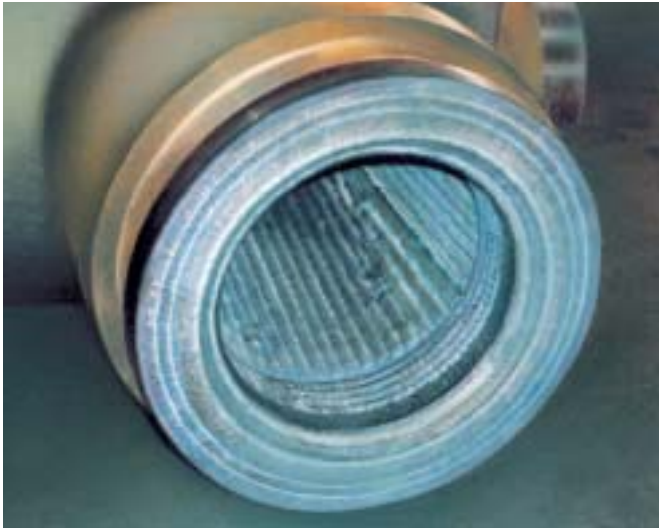

Electroless Nickel Plating

The transport of wet hydrocarbon gases contaminated with hydrogen sulphide, carbon dioxide or other similar fluids containing appreciable level

of sulphur, can create various corrosion problems to some component in plug valves. These environments are not always recognized under service conditions, therefore in order to obtain a high quality corrosion resistant, all the material for

each component of the valves, are selected in accordance with the requirements of NACE-Std. MR-01-75 Latest Edition. Moreover the use of an electroless nickel plating on plug surface provides more corrosion

protection to hydrogen sulphide crack-resistant base metal. Standard ENP is in accordance with ASTM B733 Std with a minimum 0.003" (76 Microns) thickness, unless otherwise specified in the customer's specification.

Tungsten Carbide Coating

A series of metal carbide coatings (WC+Ni, Cr or WC+Co or WC+Co, Cr), usually known as Tungsten

Carbide (WC) allow to achieve higher performance in terms of valve working life compared to conventional materials. These performances are specially highlighted in

case of severe operating conditions such as: corrosive, abrasive environments or high working temperature. Moreover, higher hardness values (greater than 1100

HV / 70 HRC) compared to standard hardfacing (Stellite 6, 37 - 40 HRC) provide a very good abrasion & wear resistance.

Actuators Availability:

Electric



Pneumatic



Electro Hydraulic

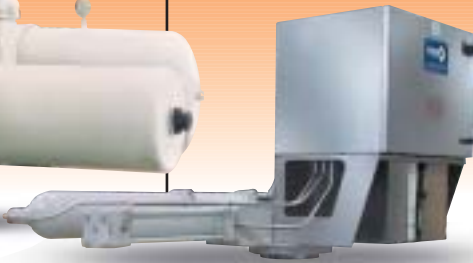

Gas Overoil





Fire Safe Test

All Galli&Cassina's Plug Valves have been tested against fire resistance, according to API - 6FA and BS 6755 - Part 2 standards and witnessed by international third party.



Metal to Metal Seat, diaphragm sealing as well as the stem sealing compound with graphite guarantees a high reliability performance of our Plug Valves while in exposure to Fire Test conditions.

Available Tests

Type of Test	Applicable Standards	Performance
X AND GAMMA RAYS	ANSI B16.34 - Annex-B ASME VIII - Div.1 - MSS - SP 54 ASTM E446 - E186 - E280	100% all butt welding ends and body.
DYE PENETRANT	ASME V - art.6 and 24 - ASTM E142 ANSI B16.34 - Annex-D MSS-SP-93	100% all butt welding ends
MAGNETIC - PARTICLES (Dry and wet)	ASME V - art.7 and 25 ANSI B16.34 - Annex C - MSS - SP 53	100% of all valves
ULTRASONIC	ASME V - art.4 and 23 ASME VIII - Div.1 - ASTM - A388	Upon customer request
VISUAL AND DIMENSIONAL	MSS - SP 55 ANSI B16.5 - B16.10 API 6D - (Table 4.2)	100% of rough and finished machined components and assembled valves
HARDNESS	NACE - MR.01.75 Latest Edition	100% of wetted components
HYDROSTATIC AND PNEUMATIC	API - 6D - API 598 BS 6755 - Part.1 - MSS - SP 61	100% of all valves
OPERATION TORQUE	API - 6D	Upon customer request
HIGH PRESSURE CLOSURE	API - 598 - par. 4-5	Upon customer request
POSITIVE MATERIAL IDENTIFICATION	ASTM A751	100% of pressure containing components





Lubricants

Galli&Cassina Plug Valves can use different types of Climax lubricant grease suitable for various services.

The operating conditions must be specified at enquiry stage enabling us to advise which type of sealant is suitable.

The lubricant grease is available as a spare part item and can be ordered as:



- **Cartridges (suitable for hydraulic gun pump).**
- **Drums (suitable for pneumatic pump). For the selection of the correct lubricant, Galli&Cassina staff is always available at the customer's request to recommend the suitable lubricant.**

Climax Hydraulic Gun No.1699

This specially designed, high pressure handgun, light in weight (appr.16 lbs.) is more rugged

than conventional types and meets exacting demands of plug valve sealants. Built for servicing plug valves, all parts are machined with minutely accuracy.

The polished hardened steel piston is perfectly fitted in the high pressure barrel to provide absolute smoothness of operation. The CLIMAX 1699 is self-priming and can be used in any position. Because of its hydraulic principle, this gun exerts more pressure than any other portable gun.

This gun is equipped with a CLIMAX 1699 Button Head Coupler for connection to the button head sealant fitting in the shank of the valve.

This coupler has a built - in feature which locks it to fitting when the gun is under positive pressure.

The coupler cannot be connected to or separated from the fitting with the gun under pressure.

This pressure may be relieved by a turn of the by-pass valve on the gun. The by-pass valve should not be closed to a point where it is jammed into its seat, nor



should it be opened tight against the stop. The valve should be closed firmly, but not tightly. It is not necessary to open the valve past one full turn. Due to "built - in" safety features, the CLIMAX 1699 provides the maximum

safety to both the valve and the gun itself. The hydraulic system of the gun is equipped with a relief fitting to protect the gun from injury if the operator were to continue to pump after the gun had been depleted of valve sealant.

Also, to prevent damage to the valve and sealant gun, in the event of sealant clogging the system or the operator pumping

too fast, a CLIMAX15000 psi gauge is optional equipment.

This accessory indicates the point at which sufficient sealant pressure has been developed within the valve. The gauge also indicates valve adjustment and other services required.

The CLIMAX 0-15000 psi gauge is the highest quality, most reliable glycerin filled gauge available.

The one piece die cast brass case and heavy duty bourdon tube and movement enable the gauge to stand up to the shock and vibration encountered on the most demanding applications. The CLIMAX gauge also features a rubber gauge protector.

A carrying case for the CLIMAX Model 1699 is optional.

Refer to the part list for available options.

Note: Gun shown is a 1699-S model complete with hose assembly, gauge, tee and "Z" swivel.

Automatic Lubrication

Galli&Cassina Plug Valves can be provided with a special automatic lubricant pump to facilitate maintenance service. The automatic pump model depends on the size of valve and its number of open/closed cycles enables

us to calculate the consumption of the lubricant grease during the operating service. The automatic pumps are available either electric or pneumatic motor type at the following operating temperature range: -20 to 40°C.

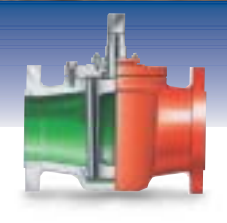
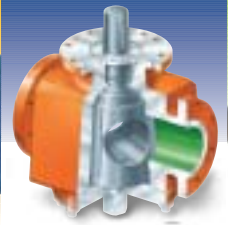
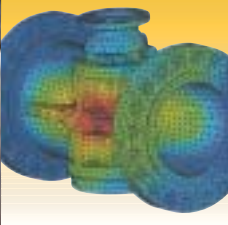

AdverTime-MI

G&C FBC-2004

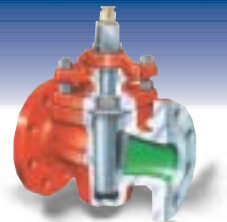

Алматы (7273)495-231
 Ангарск (3955)60-70-56
 Архангельск (8182)63-90-72
 Астрахань (8512)99-46-04
 Барнаул (3852)73-04-60
 Белгород (4722)40-23-64
 Благовещенск (4162)22-76-07
 Брянск (4832)59-03-52
 Владивосток (423)249-28-31
 Владикавказ (8672)28-90-48
 Владимир (4922)49-43-18
 Волгоград (844)278-03-48
 Вологда (8172)26-41-59
 Воронеж (473)204-51-73
 Екатеринбург (343)384-55-89

Ижевск (3412)26-03-58
 Иваново (4932)77-34-06
 Иркутск (395)279-98-46
 Калининград (4012)72-03-81
 Калуга (4842)92-23-67
 Кемерово (3842)65-04-62
 Киров (8332)68-02-04
 Коломна (4966)23-41-49
 Кострома (4942)77-07-48
 Краснодар (861)203-40-90
 Красноярск (391)204-63-61
 Курск (4712)77-13-04
 Курган (3522)50-90-47
 Липецк (4742)52-20-81

Киргизия (996)312-96-26-47

Магнитогорск (3519)55-03-13
 Москва (495)268-04-70
 Мурманск (8152)59-64-93
 Набережные Челны (8552)20-53-41
 Нижний Новгород (831)429-08-12
 Новокузнецк (3843)20-46-81
 Ноябрьск (3496)41-32-12
 Новосибирск (383)227-86-73
 Ноябрьск (3496)41-32-12
 Омск (3812)21-46-40
 Орел (4862)44-53-42
 Оренбург (3532)37-68-04
 Пенза (8412)22-31-16
 Петрозаводск (8142)55-98-37
 Псков (8112)59-10-37

Россия (495)268-04-70

Пермь (342)205-81-47
 Ростов-на-Дону (863)308-18-15
 Рязань (4912)46-61-64
 Самара (846)206-03-16
 Саранск (8342)22-96-24
 Санкт-Петербург (812)309-46-40
 Саратов (845)249-38-78
 Севастополь (8692)22-31-93
 Симферополь (3652)67-13-56
 Смоленск (4812)29-41-54
 Сочи (862)225-72-31
 Ставрополь (8652)20-65-13
 Сыктывкар (8212)25-95-17
 Сургут (3462)77-98-35
 Тамбов (4752)50-40-97

Казахстан (772)734-952-31

Тверь (4822)63-31-35
 Тольятти (8482)63-91-07
 Томск (3822)98-41-53
 Тула (4872)33-79-87
 Тюмень (3452)66-21-18
 Улан-Удэ (3012)59-97-51
 Ульяновск (8422)24-23-59
 Уфа (347)229-48-12
 Хабаровск (4212)92-98-04
 Чебоксары (8352)28-53-07
 Челябинск (351)202-03-61
 Череповец (8202)49-02-64
 Чита (3022)38-34-83
 Якутск (4112)23-90-97
 Ярославль (4852)69-52-93

<https://gallicassina.nt-rt.ru> || gnj@nt-rt.ru